



1mW Wireless Call Systems

AN426R II

Instruction Manual V1.60

Please use this Instruction manual correctly on reading well.
Please keep it carefully to be able to read immediately, when required.

CONTENTS

1. Before Use	1
1-1. Introduction	1
1-2. Main Unit and Accessories	2
1-3. Safety Precautions (Be Sure to Read This)	3
1-4. Outline	5
1-5. System Configuration	6
1-6. Specification	7
1-6-1. Transmitter AN426T II	7
1-6-2. Receiver AN426R II	7
1-7. Part Names and Descriptions	8
1-7-1. Transmitter AN426T II	8
1-7-2. Receiver AN426R II	8
1-8. Dimensional Drawing	9
1-8-1. Transmitter AN426T II	9
1-8-2. Receiver AN426R II	9
1-9. Installation	10
1-9-1. Notes for Installation	10
1-9-2. Installation of Transmitter	10
1-9-3. Installation of Receiver	10
1-9-4. Input / Output Terminal Block	11
1-9-5. Input Circuit	12
1-9-6. Output Circuit	12
2. Settings	13
2-1. Transmitter Settings	13
2-2. Receiver Settings	13
2-2-1. Channel, Set No. and Unit No. Settings	15
2-2-2. Display Method Setting	16
2-2-3. Output Time Setting	16
3. Description of Operation	17
3-1. Transmitter Operation	17
3-2. Receiver Operation	18
3-2-1. Basic Operation	18
3-2-2. Receiver Test Operation	20
4. Speaker (Option)	21
4-1. Speaker Operation	21
4-2. Sound Selection	22

5. Troubleshooting 24
6. After service and Warranty 25

1. Before Use

1-1. Introduction

This instruction manual contains necessary information for using the product, such as general description, installation, and operation of the product. We thus ask that you read the manual carefully before proceeding to use the product and keep it available at hand for ready reference whenever you need it.

This product consists of the transmitter(s) “AN426TII” (hereinafter “transmitter”) and a receiver “AN426R II” (hereinafter “receiver”). Up to eight transmitters are available.

The transmitter of this system is a device certified to comply with the technical standards for “radio equipment for specified low-power radio stations telemeter & telecontrol.”

< Information on radio equipment for telemeter & telecontrol >

Radio equipment for telemeter:

Refers to radio equipment which is intended to utilize radio waves to automatically display or record the measurement results of a remotely located measuring instrument.

Radio equipment for telecontrol:

Refers to radio equipment which is intended to utilize radio waves to transmit the signals for starting, changing, or stopping the functions of a remotely located device.

1. Do not use this system for any applications that could cause harm or damage to human life or to other equipment or devices. Also, do not use it in the vicinity of any devices that could malfunction due to the radio waves from the transmitter.
2. Disassembling or making modification to any equipment or devices certified to comply with the technical standards is prohibited by law.
3. The casing of the transmitter bears a certification label for compliance with the technical standards. Do not remove the label from the casing of the transmitter. Using the transmitter with the certification label removed is prohibited by law.
4. This equipment is exclusively for use in Japan.
It may not be used outside Japan because the applicable radio law is only effective in Japan. Besides, it may not be used in a condition that it is connected with an electrical communication line.
5. The communication performance varies depending on the ambient environment. Before installation, ensure that the installation location is within the coverage.

1-2. Main Unit and Accessories

■Transmitter AN426T II

For main unit and accessories of the transmitter, see the instruction manual “Specified Low-power 1mW Transmitter AN426T II.”

■Receiver AN426R II

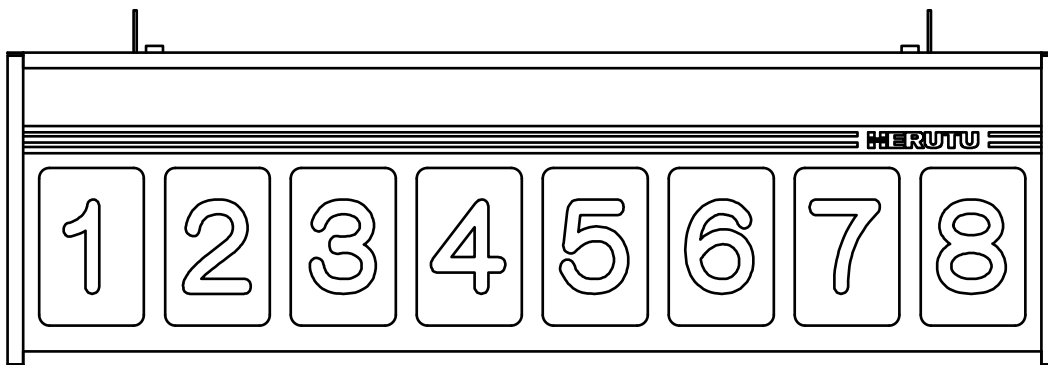

Receiver main unit AN426R II x1

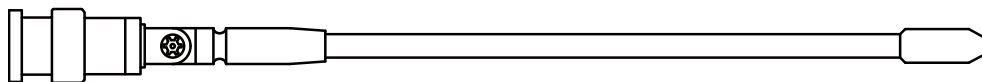



Antenna TK-1842 x1

1-3. Safety Precautions (Be Sure to Read This)

This section describes the matters to be observed in order to prevent harm to the users and other persons and damages to the property.

- The following marks and displays classify and describe the extent of harm and damage caused by failing to observe the display content and using this product wrongly.

 Warning	This display column shows "a failure to do observe it could result in death or serious personal injury".
 Caution	This display column shows "a failure to do observe it could result in only the personal injury or property damage".

Caution

- Common matters in handling



<ul style="list-style-type: none">● Avoid using this product in the humid or dusty place. Dusts or water enters the product, which may cause the fault, fire, or electric shock.	
--	---

- Handling this product

<ul style="list-style-type: none">● This product is the wireless communication equipment made of precision parts. Do not disassemble or modify it. Or the accident or fault may occur.	
--	---



Warning









- Handling this product

<ul style="list-style-type: none">● Do not use this product for application that requires the extremely high reliability affecting the human life.	
<ul style="list-style-type: none">● Do not use this product in the area which the radio wave reaches or not.	

- Handling the power supply



Be sure to observe the followings in order to prevent the accidents such as heat generation, damage, or ignition of AC adapter and power cord.

<ul style="list-style-type: none">● Do not place the AC adapter and power cord close to fire or insert them into fire. Or they may be burst and ignited, resulting in the accident.	
<ul style="list-style-type: none">● Use the AC adapter and main body only at the specified power supply voltage in order to prevent burst and ignition accidents.	

<ul style="list-style-type: none"> Do not use the AC adapter and main body at the location where they easily get wet. Or the accidents including heat generation, ignition, or electric shock and faults may occur. 	
<ul style="list-style-type: none"> Do not touch the AC adapter, main body, power cord, and outlet with wet hands. Or the accident such as an electric shock may occur. 	
<ul style="list-style-type: none"> Do not damage the power cord. Short-circuit or heat generation may cause fire or electric shock. 	
<ul style="list-style-type: none"> Do not use the power plug with dusts attached. Short-circuit or heat generation may cause fire or electric shock. 	
<ul style="list-style-type: none"> Do not give a strong shock to the AC adapter. Or the accident or fault may occur. 	
<ul style="list-style-type: none"> If you find a deformation in the AC adapter, do not use it. Or the accident or fault may occur. 	
<ul style="list-style-type: none"> Do not charge the main body at the location where the flammable gas is generated. Or the ignition accident may occur. 	
<ul style="list-style-type: none"> Never disassemble the AC adapter. Or the accident or fault may occur. 	

■ Never disassemble the AC adapter.

Remove the power plug from the outlet because it may cause fire and electric shock. Request the dealer or our company to repair it.

<ul style="list-style-type: none"> When smoke comes or there is a strange smell, immediately stop usage and remove the power plug from the outlet because it may cause fire and electric shock. Request the dealer or our company to repair it. 	
<ul style="list-style-type: none"> If the cord is damaged, do not use it. Using the cord damaged continuously may cause fire or electric shock. 	

■ Reliability of wireless communication

As wireless communication has properties that are different from those of wired communication, communication errors may occur due to the following.

- Exceeds the communication distance.
- Enters a dead zone.
- Interfered by strong jamming

If signals are often jammed, or being jammed leads to operational problems, stop using the systems and restart using the systems after removal of the cause.

Radio waves may not be received due to various reasons other than the above. Please understand this before using the systems.

*A dead zone is an area where the radio wave transmitted from the transmitter becomes extremely weak due to radio waves reflected from walls or other objects.

1-4. Outline

1. You can monitor up to eight trouble occurrence reports with a single receiver and eight transmitters AN426T II.

At the transmitter, there are two selectable input methods: one with four push buttons (1 (orange), 2 (red), 3 (green), 4 (white)) and one with four external inputs (1 (orange), 2 (red), 3 (green), 4 (white)). According to possible trouble occurrences in the production line, you can assign each color a meaning, such as red for an exception occurrence, orange for parts out of stock, green for requesting transportation of finished products, or white for trouble solved.

The indicator with the same number as the kiki number set in the transmitter lights up (or blinks).

2. The receiver performs the external outputs (open collector outputs and relay output) in synchronization with the lighting (or blinking) of the indicator.
3. Since the communication channels can be set from 1CH to 10CH, interference can be prevented even when multiple receivers are installed.

In addition, 10 set numbers and 10 unit numbers can be set for each channel, so it is possible to identify up to 1,000 receivers.

* The transmitter and the receiver are shipped with the same communication channel, set number, and unit number set.

4. The receiver is a double-sided display type.
5. You can select the display method of the indicator from lighting or blinking. It is possible to set the display method for push button input and external input individually. For the display method, refer to "2-2-2. Display Method Setting".
6. In addition to the indicator lights, an optional speaker can be installed that enables sound notifications. A different melody for each indicator color can be configured (when multiple colors are illuminated, the melody is selected according to the priority order). For details on the speaker, refer to "4. Speaker (Option)".

1-5. System Configuration

This product consists of the following devices.

1. 1mW transmitter AN426T II

At the transmitter, there are two selectable input methods: one with four push buttons (1 (orange), 2 (red), 3 (green), 4 (white)) and one with four external inputs (1 (orange), 2 (red), 3 (green), 4 (white)). The transmitter transmits a radio signal according to the input signal.

For details on the transmitter, refer to the instruction manual for “Specified Low-power 1mW Transmitter AN426T II”.

2. Receiver AN426R II

- The receiver lights up (or blinks) each indicator independently for corresponding calls from the transmitter. The indicator numbers 1 to 8 correspond to the kiki numbers set in the transmitter. The indicator can be displayed in three colors: orange, red, and green.
- The receiver performs 4 open collector outputs and 1 relay output in synchronization with the lighting (or blinking) of the indicator. The output time can be selected from “continuous” or “5 seconds”. For the output time, refer to “2-2-3. Output Time Setting”.

This system supports calling distant people and machines of the production line.

AN426R II can be used in combination with eight AN426T II transmitters.

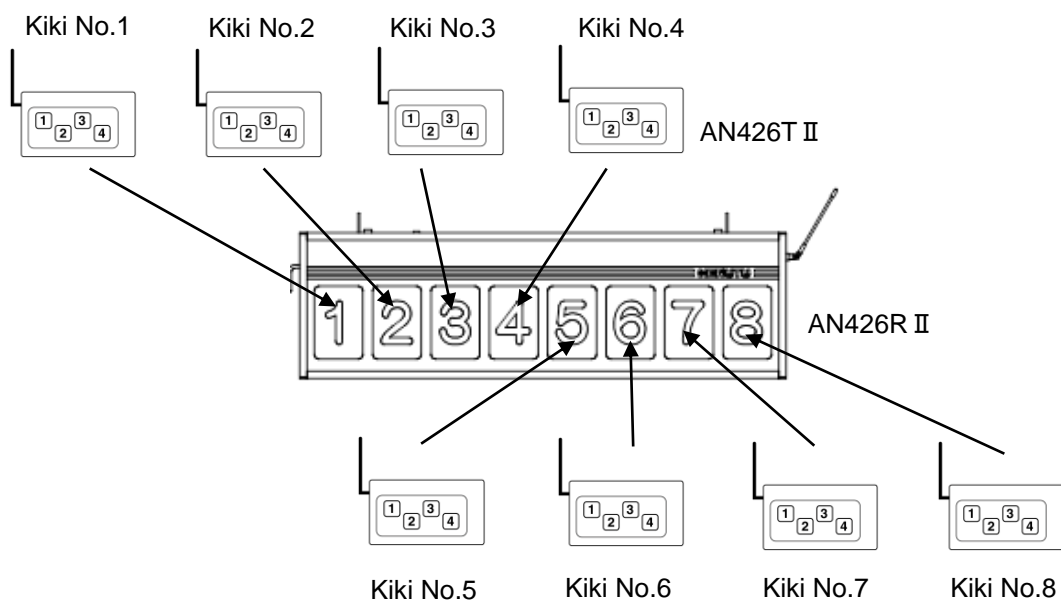

1-6. Specification

1-6-1. Transmitter AN426T II

For details on the transmitter, refer to the instruction manual for “Specified Low-power 1mW Transmitter AN426T II”.

1-6-2. Receiver AN426R II

Item	Specification
Frequency Band	426.0250MHz - 426.1375MHz (12.5kHz steps - 10 channels)
Type of Radio Wave	F1D
Antenna	$\lambda/4$ Whip Antenna
Modulation System	Direct 2-FSK Modulation
Modulation Speed	977bps
Communication	Receive only
Outputs	4 Open Collector Outputs (Max. Rated Load DC 35V 50mA) 1 Relay Output (Photo MOS relay) (Max. Related Load AC/DC 30V 0.5A)
Inputs	2 Non-voltage Contact-Inputs 1 Reset ALL / 1 Reset Output * Output: Open collector outputs / Relay output
Indicator Element	8 Indicator Lamps (Indicator Dimensions (HxW) 150x100 mm (5.9x3.9")) Double-Sided Indicator 3-Color LED (Orange, Red, Green) * For orange, the color tone may slightly vary.
Power Source	AC 100V (AC 100-120V)
Wattage	Max.90W
External Dimensions	(WxHxD) 1,000 × 300 × 80 mm (39.4x11.8x3.1") (except any protruding object such as an antenna)
Weight	Approx. 8 kg *The weight of the receiver with an optional speaker is approx.1.7kg heavier than that of a receiver without a speaker.
Operating Environment	Temperature: 0 - +40°C(32-104°F) Humidity: 85% or less (without condensation)
Setting Switches	1 Switch (8-Position DIP) 3 Switches (10-Position Rotary each) (for setting Channel, Set No., Unit No.)
Included	1 Antenna

1-7. Part Names and Descriptions

1-7-1. Transmitter AN426T II

For details on the transmitter, refer to the instruction manual for “Specified Low-power 1mW Transmitter AN426T II”.

1-7-2. Receiver AN426R II

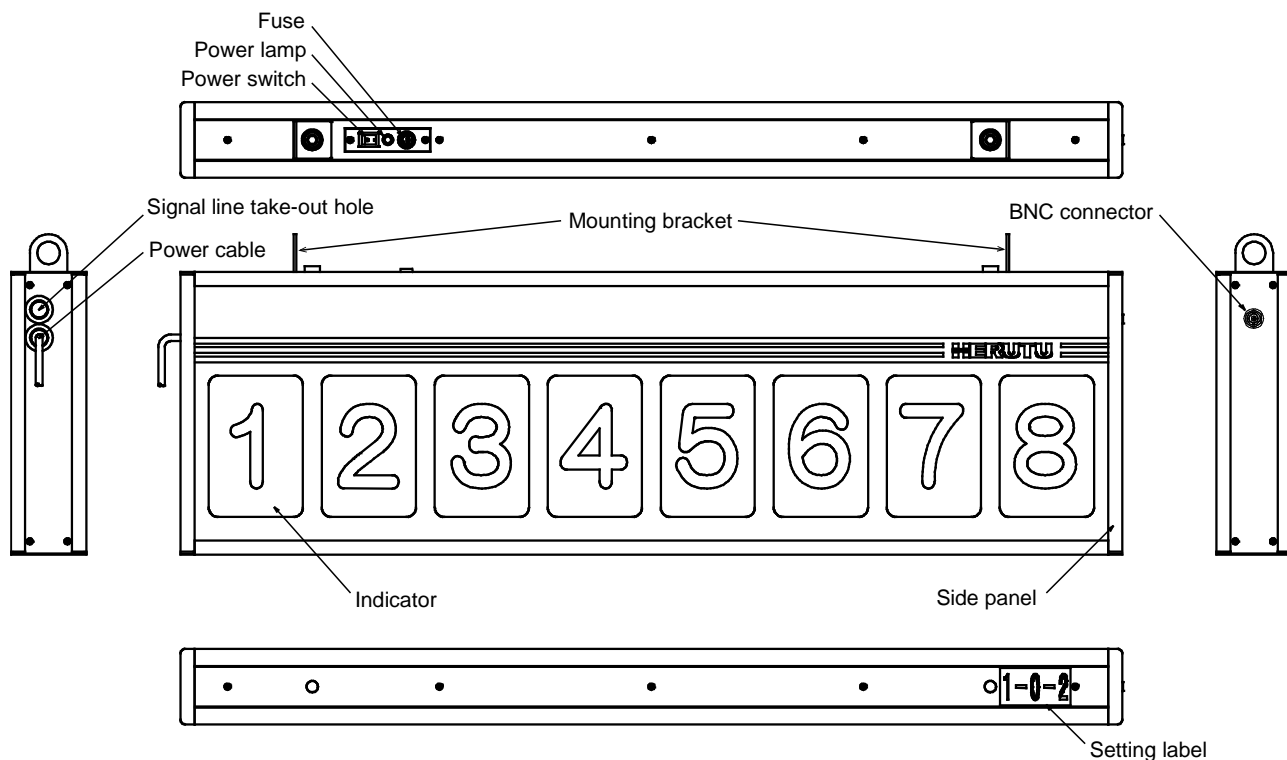

Item	Description
Mounting bracket	Use the mounting metal fittings for fixing the receiver.
BNC connector	Connects the included antenna.
Signal line take-out hole	Connect the signal lines to the internal input/output terminal block by drawing them through this takeout hole.
Power cable	Power cable with a plug (approx. 1.5 m)
Fuse	AC125 V fuse. (For fuse capacity, see the affixed seal.)
Power lamp	Lamp for the power source. Lights up when the power source is switched on.
Power switch	Power switch of the main unit.
Indicator	3-Color LED (Orange/ Red/ Green). The receiver illuminates each indicator independently for corresponding calls from the transmitter. The indicator corresponding to the kiki No. of the transmitter lights up (or blinks).
Side panel	Remove the side panel to connect signal lines to the input/output terminal block or configure Channel, Unit No., Set No. and Display method.
Setting label	Label showing factory default Channel/ Set No./ Unit No. e.g. "1-0-2" : Channel 1/ Set No. 0/ Unit No. 2

1-8. Dimensional Drawing

1-8-1. Transmitter AN426T II

For details on the transmitter, refer to the instruction manual for “Specified Low-power 1mW Transmitter AN426T II”.

1-8-2. Receiver AN426R II

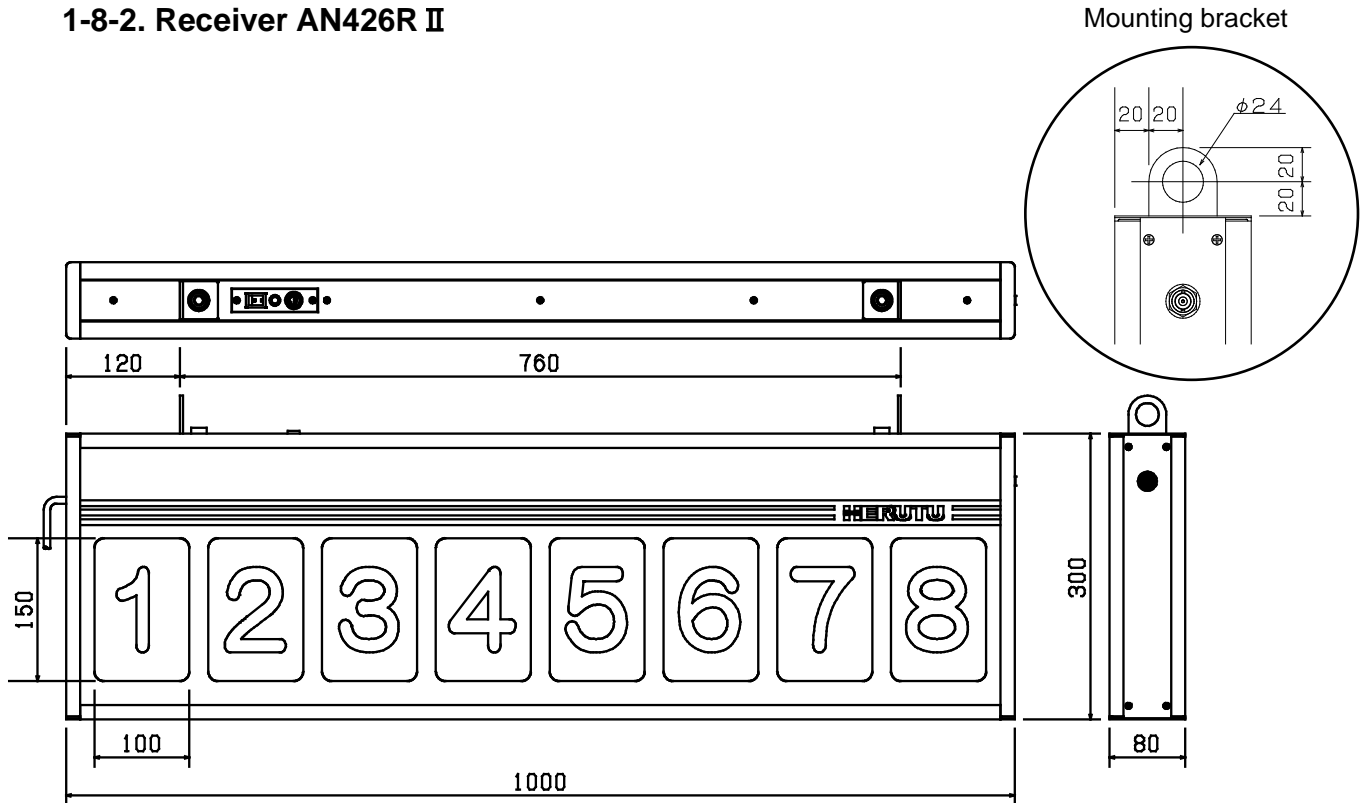

Option (AN426R II -MRD)

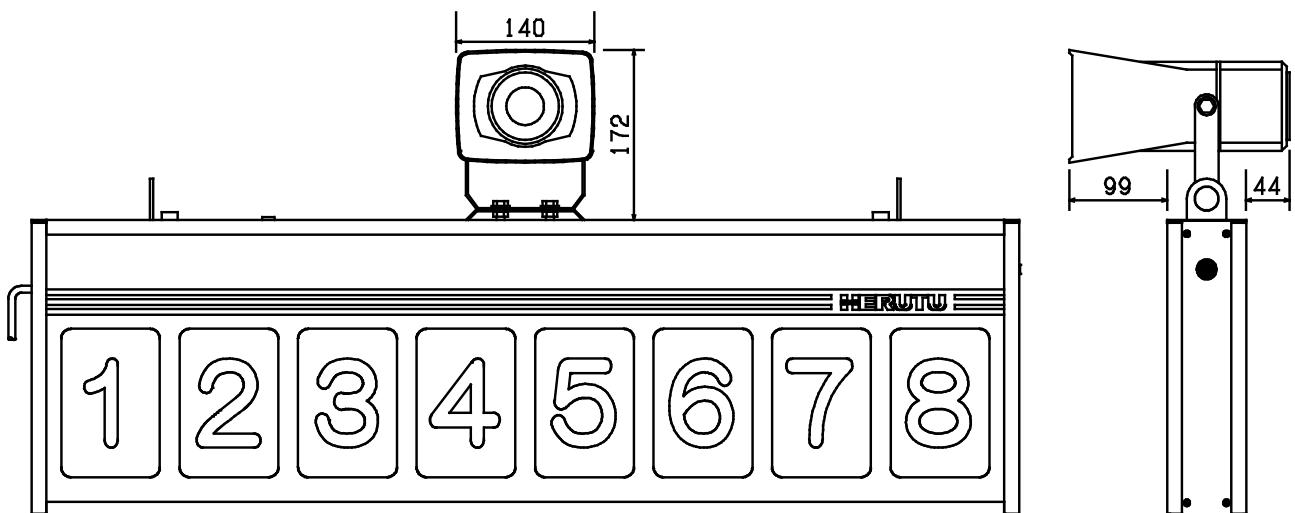

*The weight of the receiver with an optional speaker is approx. 1.7kg heavier than that of a receiver without a speaker. Please be careful when installing.

1-9. Installation

1-9-1. Notes for Installation

When installing the product, pay attention to the following:

1. Keep the antenna away from metal sheets or wires and do not set it alongside the side panel of the annunciator.
2. Keep the antenna away from noise sources.
3. For installation, choose a location where there are no shielding objects between the antennas of the transmitter and the annunciator.
4. The communication performance largely depends on the installation environment. Before installation, make sure if the installation location is within the coverage.
5. This system (transmitter and annunciator) is not dust-proof or drip-proof in construction.

* For installation, avoid choosing such locations as:

- Within reach of direct sunlight
- In the presence of an extremely high level of moisture
- In the vicinity of TV or radio
- In the vicinity of sparking devices such as a welding machine
- In the presence of an intense magnetic field
- In an area surrounded by iron frames or metallic walls

1-9-2. Installation of Transmitter

For details on the transmitter, refer to the instruction manual for “Specified Low-power 1mW Transmitter AN426T II”.

1-9-3. Installation of Receiver

Install the receiver where it can be seen easily and clearly from the transmitter. When using the mounting fittings, secure the receiver to a location stable enough to support the weight (approx. 8 kg).

Direct the antenna diagonally upward. Do not direct it downward in parallel with the side of the receiver.

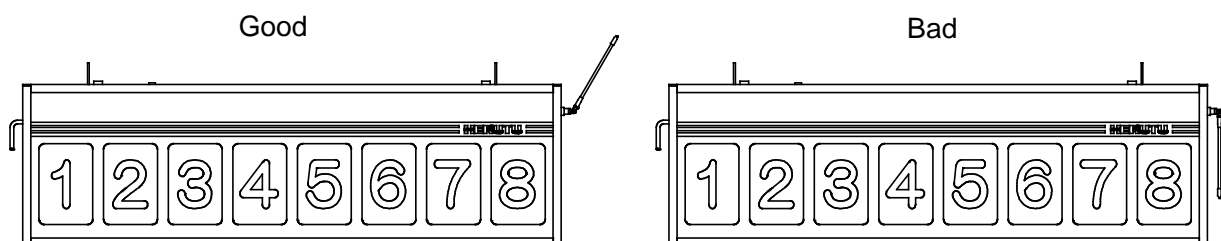

1-9-4. Input / Output Terminal Block

External outputs in synchronization with LED illumination are generated at the input/output terminal block inside.

Set the antenna perpendicular to the side panel and remove the screws (4) securing the side panel. Move the side panel off the main unit while taking care not to hitch it on the antenna.

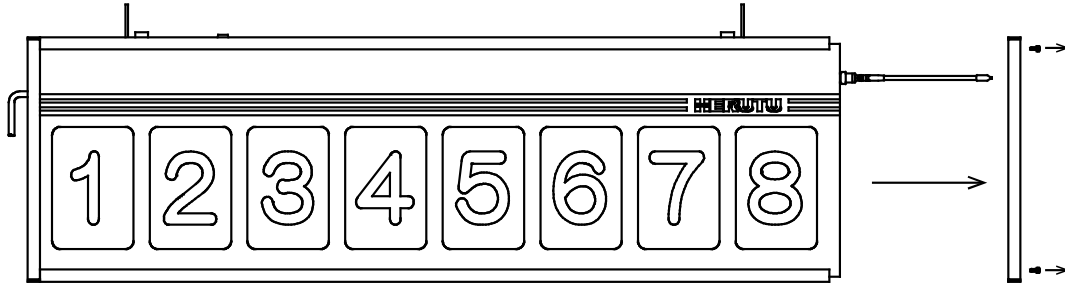

As the input/output terminal block is on the back side, remove the acrylic sheet on the back by sliding it out.

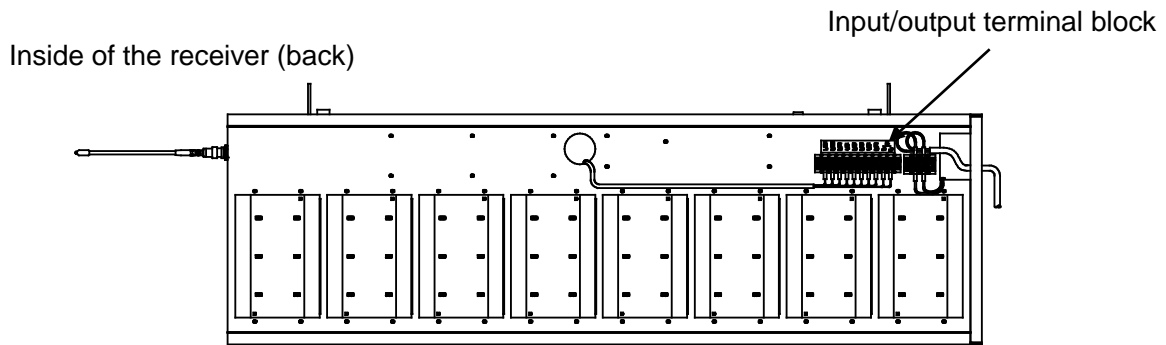

Input/output terminal block

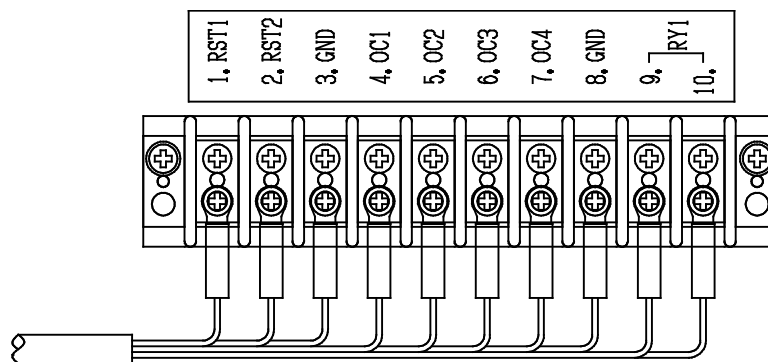

- 1.RST1 : All reset input (Returns the settings to default.)
- 2.RST2 : Output reset input (Stop external output.)
- 4.OC1 : Open collector output (Synchronized with orange LED illumination.)
- 5.OC2 : Open collector output (Synchronized with red LED illumination.)
- 6.OC3 : Open collector output (Synchronized with green LED illumination.)
- 7.OC4 : Open collector output (Synchronized with orange/ red/ green LED illumination.)
- 9/10.RY1 : Relay output (Synchronized with orange/ red/ green LED illumination.)

Pass the signal lines through the signal line takeout hole before connecting it to the terminal block.

*Input/output terminal block: M3 screw

1-9-5. Input Circuit

For the Non-voltage contact input to be connected to the “All Reset” Input and “Output Reset” Input, use the circuit with less chattering which can steadily turn on/off the voltage/current of DC5V/15mA.

Reset Input Circuit

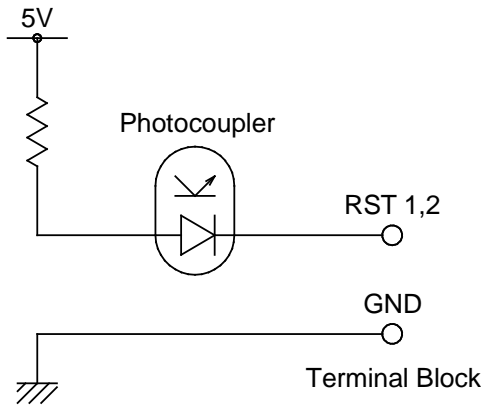

1-9-6. Output Circuit

The maximum rated load of open collector output is DC35V 50mA.

Open Collector Output circuit

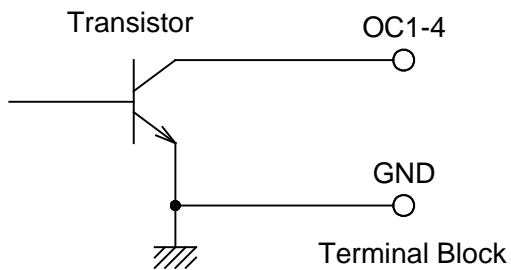

The maximum rated load of relay output is AC/DC30V 0.5A.

Relay Output Circuit

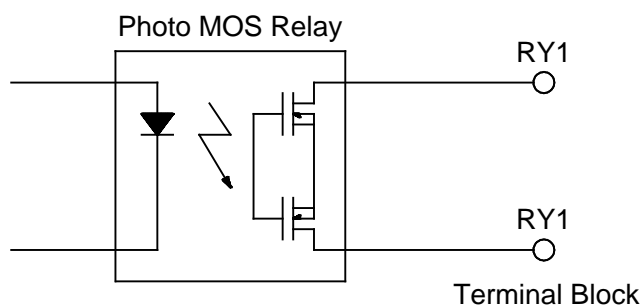

2. Settings

2-1. Transmitter Settings

For details on how to set the transmitter, refer to the instruction manual for “Specified Low-power 1mW Transmitter AN426T II”. When you use the transmitter(s) in combination with this product, set the operation mode and the kiki number as follows:

Item	Configuration content
Operation mode	The transmitter has two operation modes: AN426T II mode and AN426T mode (earlier mode). <u>Select the AN426T II mode.</u>
Kiki number	<u>Set the kiki number of the transmitter within the range of 1 to 8.</u> The kiki numbers 0 and 9 are not available. The receiver lights up (or blinks) the indicator with the same number as the kiki number of the transmitter.

2-2. Receiver Settings

The receiver has the following setting items.

***Please turn off the power before changing the settings.**

Item	Description	Reference item
Channel	Since channels can be set from 1CH to 10CH, interference can be prevented even when multiple receivers are installed. Configure the receiver channel to match the transmitter.	2-2-1. Channel, Set No. and Unit No. Settings
Set No.	This is a setting to identify the receiver. Configure the receiver settings to match the transmitter.	
Unit No.		
Display method	Set the display method (lighting or blinking) of the indicator. This setting can be configured separately for push buttons and external inputs.	2-2-2. Display Method Setting
Output time	Set the open collector output time and relay output time.	2-2-3. Output Time Setting

Configure each setting using the RSW1, RSW2, and RSW3 (rotary switches 1-3) and the DSW1 (DIP switch 1) on the CPU board inside the receiver.

Set the antenna perpendicular to the side panel and remove the screws (4) securing the side panel. Move the side panel off the main unit while taking care not to hitch it on the antenna.

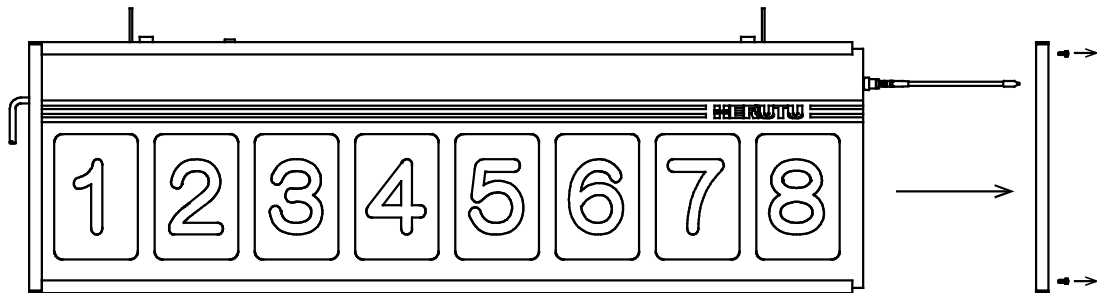

As the CPU board is in the front, remove the front acrylic sheet by sliding it out.

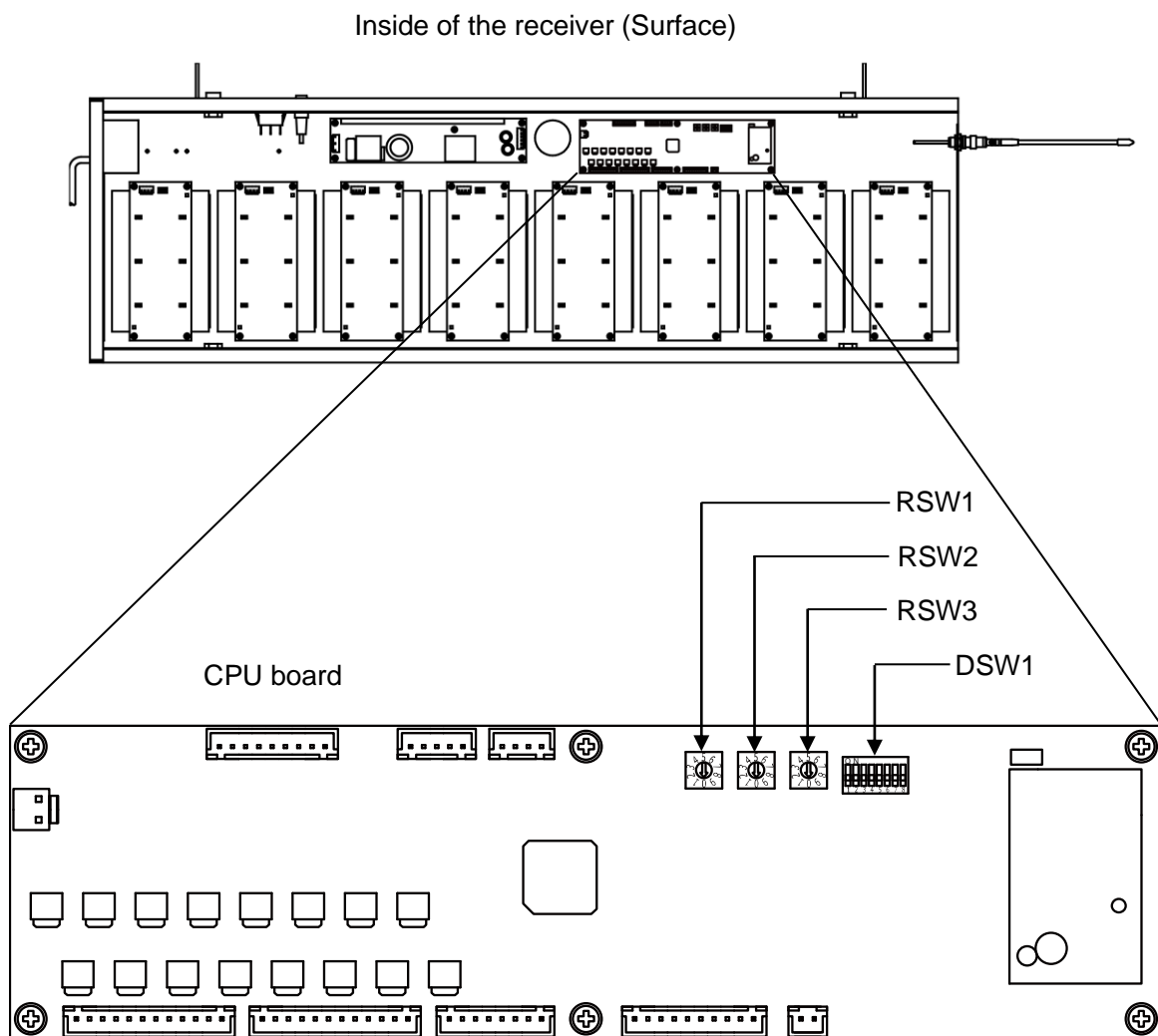

2-2-1. Channel, Set No. and Unit No. Settings

Configure the settings of the channel, the set number, and the unit number to match the transmitter.

< Channel >

RSW1	Channel	Frequency (MHz)	RSW1	Channel	Frequency (MHz)
1	1	426.0250	6	6	426.0875
2	2	426.0375	7	7	426.1000
3	3	426.0500	8	8	426.1125
4	4	426.0625	9	9	426.1250
5	5	426.0750	0	10	426.1375

< Set No. >

RSW2	Set No.
0	0
1	1
2	2
3	3
4	4
5	5
6	6
7	7
8	8
9	9

< Unit No. >

RSW3	Unit No.
0	0
1	1
2	2
3	3
4	4
5	5
6	6
7	7
8	8
9	9

The setting of the channel, the set number, and the unit number can be confirmed by the lighting pattern of the indicator at power on. The indicators light in the order of the channel (green), the set number (orange), and the unit number (red).

Channel (1-10) Set No. (0-9) Unit No. (0-9)	Lighting pattern
0	All indicators light up
1	Indicator 1 lights up
2	Indicator 2 lights up
3	Indicator 3 lights up
4	Indicator 4 lights up
5	Indicator 5 lights up
6	Indicator 6 lights up
7	Indicator 7 lights up
8	Indicator 8 lights up
9	Indicator 1 and 8 light up
10	Indicator 2 and 8 light up

Example of display:

Channel 9
Set No. 4
Unit No. 0

Channel: Indicator 1 and 8 light up in green

↓

Set No.: Indicator 4 lights up in orange

↓

Unit No.: All indicators light up in red

2-2-2. Display Method Setting

Set the display method using the DSW1-1 and DSW1-2.

The display method can be configured separately for push buttons and external inputs.

Status of the DSW1-1	OFF	ON
Push buttons	Lighting	Blinking

Status of the DSW1-2	OFF	ON
External inputs	Lighting	Blinking

2-2-3. Output Time Setting

Set the open collector output time and relay output time using the DSW1-3.

You can select from the following two output times.

- Continuous outputThe receiver outputs continuously in synchronization with lighting (or blinking) of the indicator.
- Output for 5 secondsThe receiver outputs for 5 seconds in synchronization with lighting (or blinking) of the indicator.

Status of the DSW1-3	OFF	ON
Output time	Continuous	5 seconds

*Please do not change DSW1-4, DSW1-5, DSW1-6, DSW1-7 and DSW1-8.

Changing the factory settings may cause the receiver to malfunction.

3. Description of Operation

3-1. Transmitter Operation

For the operation of the transmitter, refer to the instruction manual for “Specified Low-power 1mW Transmitter AN426T II”.

At the transmitter, there are two selectable input methods: one with four push buttons (1 (orange), 2 (red), 3 (green), 4 (white)) and one with four external inputs (1 (orange), 2 (red), 3 (green), 4 (white)). According to possible trouble occurrences in the production line, you can assign each color a meaning, such as red for an exception occurrence, orange for parts out of stock, green for requesting transportation of finished products, or white for trouble solved.

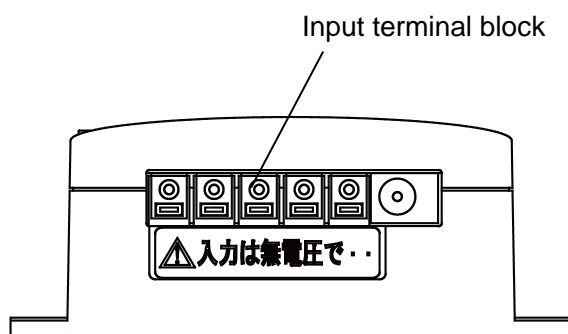
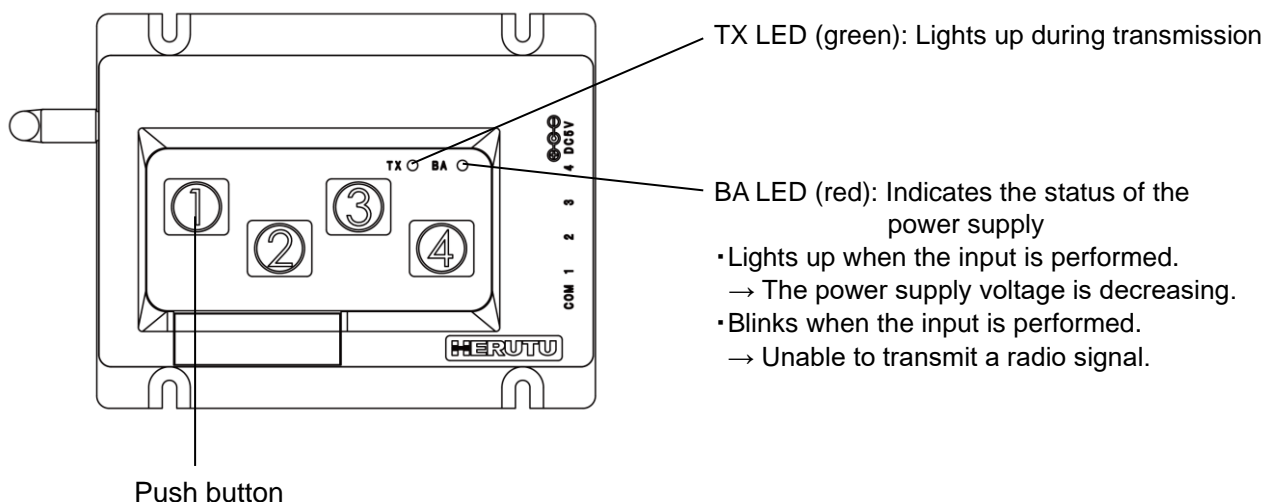

3-2. Receiver Operation

3-2-1. Basic Operation

When the receiver receives a signal transmitted from the transmitter, the indicator with the same number as the kiki number set in the transmitter lights up (or blinks), and the receiver generates the relay output and the open collector outputs.

The indicator illuminates in the same color as the transmitter push button or external input. Also, the open collector outputs (OC1, OC2, OC3) are generated from the terminal block that is assigned according to the lighting color.

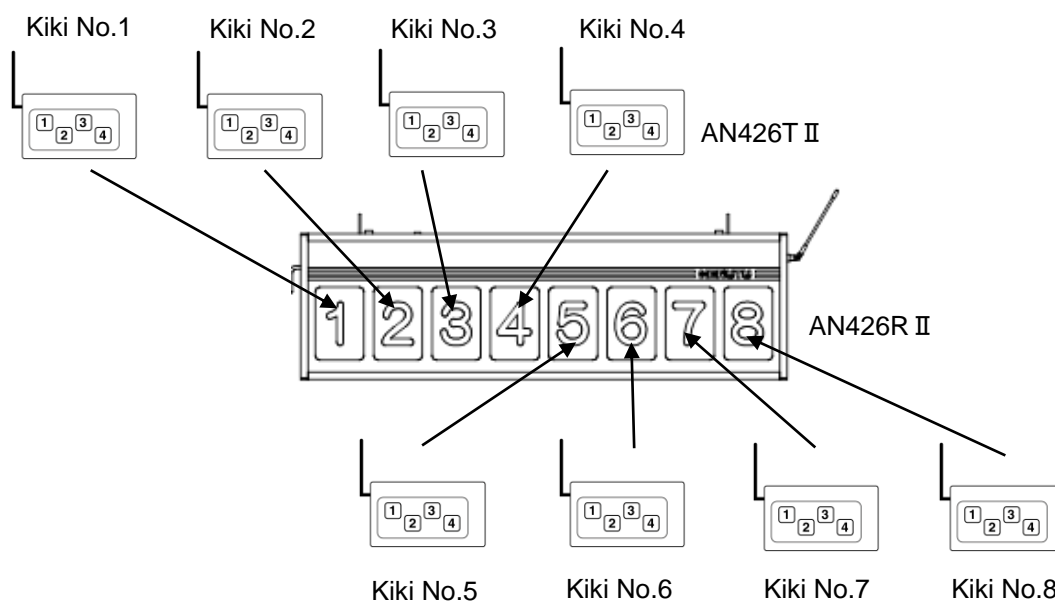

- The indicator with the same number as the kiki number set in the transmitter lights up (or blinks).
- The push buttons are not prioritized. The signal received later takes priority.
- If multiple push buttons on the same transmitter are pressed at the same time, the radio signals transmitted from transmitter are made invalid. The receiver status does not change.
- If the signals are input simultaneously to multiple external input terminals of the same transmitter, the signals transmitted from the transmitter are made invalid. The receiver status does not change.

The operation of the transmitter differs between the push button and external input.

■Action performed when the push buttons of transmitter are operated

When using the push buttons, the operation of the receiver is as follows regardless of the transmission mode of the transmitter.

Example) Operation of the receiver when the push buttons of transmitter Kiki No.1 are pressed.

Push button	Receiver operation		
	Indicator 1	Relay output Terminal block: RY1	Open collector output Terminal block: OC1-OC4
1 (orange)	Lights up or blinks in orange	ON (Continuous output or 5 seconds)	OC1/OC4 ON (Continuous output or 5 seconds)
2 (red)	Lights up or blinks in red	ON (Continuous output or 5 seconds)	OC2/OC4 ON (Continuous output or 5 seconds)
3 (green)	Lights up or blinks in green	ON (Continuous output or 5 seconds)	OC3/OC4 ON (Continuous output or 5 seconds)
4 (white)	OFF	OFF	OFF

■Action performed when the external inputs of transmitter are used

The operation of the receiver differs depending on the transmission mode set for the transmitter.

There are two types of transmission modes: event transmission and normal transmission.

For details on the transmission modes, refer to the instruction manual for “Specified Low-power 1mW Transmitter AN426T II”.

Event transmission

While the external input (1 (orange)/ 2 (red)/ 3 (green)) of the transmitter is performed, the receiver lights up (or blinks) the indicator in the color according to the input and generates the external outputs. When the external input of the transmitter is turned off, the receiver turns off the indicator lamp and stops the external outputs.

Example) Operation of the receiver when the external inputs of transmitter Kiki No.1 are used.

External input terminal	Receiver operation		
	Indicator 1	Relay output Terminal block: RY1	Open collector output Terminal block: OC1-OC4
1 (orange) (Hold the ON state)	Lights up or blinks in orange	ON (Continuous output or 5 seconds)	OC1/OC4 ON (Continuous output or 5 seconds)
2 (red) (Hold the ON state)	Lights up or blinks in red	ON (Continuous output or 5 seconds)	OC2/OC4 ON (Continuous output or 5 seconds)
3 (green) (Hold the ON state)	Lights up or blinks in green	ON (Continuous output or 5 seconds)	OC3/OC4 ON (Continuous output or 5 seconds)
4 (white)	—	—	—

Normal transmission

While the external input (1 (orange)/ 2 (red)/ 3 (green)) of the transmitter is performed, the receiver lights up (or blinks) the indicator in the color according to the input and generates the external outputs. Even if the external input of the transmitter is turned off, the receiver holds its status.

When the external input (4 (white)) of the transmitter is turned on, the receiver turns off the indicator lamp and stops the external outputs.

Example) Operation of the receiver when the external inputs of transmitter Kiki No.1 are used.

External input terminal	Receiver operation		
	Indicator 1	Relay output Terminal block: RY1	Open collector output Terminal block: OC1-OC4
1 (orange)	Lights up or blinks in orange	ON (Continuous output or 5 seconds)	OC1/OC4 ON (Continuous output or 5 seconds)
2 (red)	Lights up or blinks in red	ON (Continuous output or 5 seconds)	OC2/OC4 ON (Continuous output or 5 seconds)
3 (green)	Lights up or blinks in green	ON (Continuous output or 5 seconds)	OC3/OC4 ON (Continuous output or 5 seconds)
4 (white)	OFF	OFF	OFF

3-2-2. Receiver Test Operation

The receiver has two types of functions: indication test and external output test.

Indication test.....You can confirm that the red LEDs and green LEDs of indicator 1 to 8 light up normally.

(The orange color is generated by lighting the red and green LEDs simultaneously.)

External output test...You can confirm that the relay output (RY1) and open collector outputs (OC1-OC4) operate normally.

Operate the push buttons on the transmitter to start the receiver test.

When the receiver receives a test signal from the transmitter, it operates as follows:

Test item	Operating method of the push buttons	Receiver operation
Indication test	Press 1 (orange), 2 (red) and 4 (white) simultaneously	The receiver lights up from indicator 1 to 8 in order in red, and then lights up from indicator 1 to 8 in order in green. (Each indicator lights up for 0.5 seconds.)
External output test	Press 1 (orange), 3 (green) and 4 (white) simultaneously	The receiver generates the relay output (RY1) for 0.5 seconds and then generates the open collector outputs (OC1-OC4) for 0.5 seconds.

*The receiver does not receive a signal from the transmitter during the test operation.

*There may be a deviation of the timing of pressing the push buttons, and the signal of the first pressed button may be transmitted. In this case, the receiver test is not performed.

4. Speaker (Option)

4-1. Speaker Operation

The speaker can be installed on the top of the receiver and it produces sound in synchronization with the lighting (or blinking) of the indicators.

A different melody for each indicator color can be configured.

* When multiple colors are illuminated, the melody is selected according to the priority order.

*As the sounds are generated by using the open collector outputs "OC1-OC3", the open collector outputs cannot be used for connection of other devices.

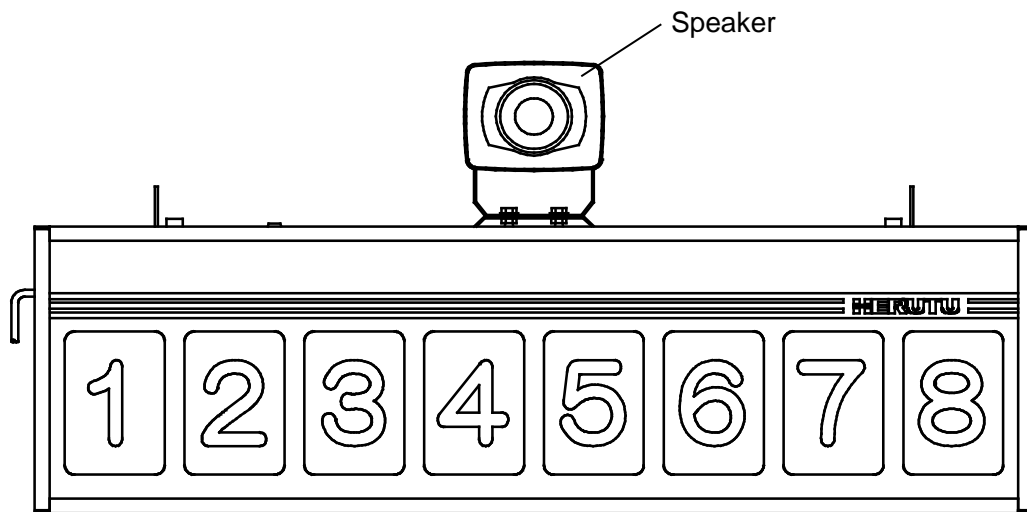

AN426R II -MRD

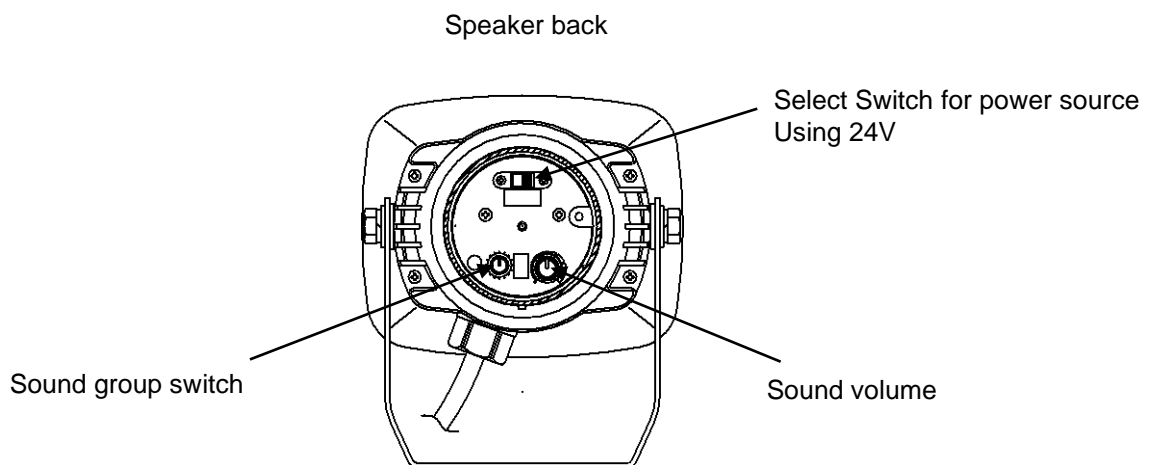

4-2. Sound Selection

The speaker sounds can be selected from 15 groups.

The receiver is shipped with a Shneider's speaker "ST-25MM"(or "ST-25MM2")connected as follows.

Output OC1: In synchronization with orange LED indication (push button or external input 1 (Orange))

⇒ Connected to CH1 of the speaker

Output OC2: In synchronization with red LED indication (push button or external input 2 (Red))

⇒ Connected to CH2 of the speaker

Output OC3: In synchronization with green LED indication (push button or external input 3 (Green))

⇒ Connected to CH3 of the speaker

When multiple signals are input, the speaker sounds a melody based on the following priority:

CH1 > CH2 > CH3

To change the indicator color (orange, red and green) and sound (and priority order), change the connection of the terminal block inside the receiver.

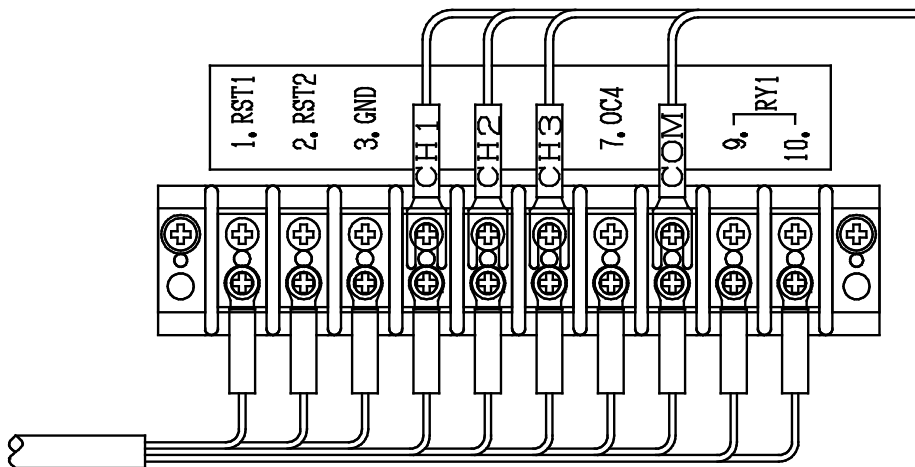

The speaker sound can be selected from 15 sound groups A-O. Select your desired sound group and set the sound using the sound changeover switch of the speaker.

■ Settings of the speaker sounding time

The speaker sounding time can be selected from continuous or 5 seconds by the internal settings. For the setting method, refer to "2-2-3. Output Time Setting".

*The speaker is set to continuous output setting at factory default.

*The speaker volume can be adjusted between 0 and 102dB without steps using the volume control.

Speaker(ST-25MM) sounds list

Group	Color of line from speaker			
	CH1(Green)	CH2(Yellow)	CH3(Brown)	CH4(Blue)
A	ASHITA GA ARUSA	ELECTRICAL PARADE	SAZAE-SAN	TOUTCH
B	CHIME	PiPiPiPi	KINJIRARETA ASOBI	KATSUSHYA
C	KINJIRARETA ASOBI	KATSUSHYA	SHEEP OF MERY	KUSAKEIBA
D	CHIME	PiPiPiPi	SHEEP OF MERY	KUSAKEIBA
E	CHIME	PiPiPiPi	FLICKER	PiLaLa
F	CHIME	PiPiPiPi	AMARYLLIS	MOZART'S 40TH
G	AMARYLLIS	MOZART'S 40TH	ASHITA GA ARUSA	ELECTRICAL PARADE
H	CHIME	PiPiPiPi	ASHITA GA ARUSA	ELECTRICAL PARADE
I	PiLaLa	DOWN	EMERGENCY	FLICKER
J	CHIME	PiPiPiPi	SAZAE-SAN	TOUTCH
K	SHEEP OF MERY	KUSAKEIBA	AMARYLLIS	MOZART'S 40TH
L	EMERGENCY	FLICKER	CHIME	PiPiPiPi
M	DOWN	EMERGENCY	CHIME	PiPiPiPi
N	PiLaLa	FLICKER	SHEEP OF MERY	KUSAKEIBA
O	DOWN	EMERGENCY	SAZAE-SAN	TOUTCH

CH4(Blue) is no connected at shipment.

5. Troubleshooting

Symptom	Possible causes & Remedy
All indicators do not light up.	Are the receiver and transmitter properly installed?
	→Refer to "1-9. Installation" and install them correctly according to the precautions.
	Is the fuse blown?
	→ Remove the fuse from the fuse holder and check. If the fuse is blown, replace it after making sure there is no other error in the power supply etc.
The indicators do not light correctly.	Are there any differences in the channel, the set number and the unit number between the receiver and the transmitter?
	→Configure the channel, the unit number and the set number to match the transmitter. For the setting method of the receiver, refer to "2-2. Receiver Settings". For details on how to set the transmitter, refer to the instruction manual for "Specified Low-power 1mW Transmitter AN426T II".
	Is any other transmitting device emitting radio waves?
	→There may be interference with radio waves from other transmitters. Wait a few seconds and then operate the transmitter again. If you are using the external input of the transmitter, check the connection to the input terminal block.
	Is the system being used outside its coverage?
	→Use it within the coverage. (A coverage check should be performed when installing the system.)

6. After service and Warranty

If something is wrong. If you should find anything wrong with the machine when using it under normal conditions, check the warranty and repair regulations and contact the outlet store through which you purchased the product or our Sales Office. The latest warranty and repair regulations can be found on our website.

The user is prohibited by law from disassembling or making modification to the unit or otherwise may be subject to punishment.

[Warranty Regulation]

This regulation (hereinafter referred to as the "Regulation") is for post-shipment warranty provided by HERUTU ELECTRONICS CORPORATION (hereinafter referred to as the "Company") so that you can use the Company's product you have purchased with confidence. The Regulation does not apply to special order products (custom products). In addition, purchased products shall be subject to the relevant manufacturer's warranty regulations, and the Regulation shall not apply.

Please note that in the event that the product you purchased comes with an instruction manual that describes the Company's old repair regulation, the latest Regulation will still apply.

1. Warranty period

Unless otherwise specified, the warranty period shall be "up to thirteen months from the date of shipment of the product by the Company". During the warranty period, the Company will replace the product with a new one or repair it free of charge in accordance with the provisions of the Regulation.

In addition, if a failure occurs during the warranty period due to the Company's responsibility and the product with the failure (hereinafter referred to as the "Product") is replaced with a new one or repaired free of charge, the warranty period of the Product will be "thirteen months from the date of initial shipment of the Product, or six months from the date of shipment of the Product that has been replaced or repaired, whichever comes later".

The warranty period for paid repairs shall be in accordance with the provisions of the Company's repair regulation.

2. Warranty scope

If a failure occurs during the warranty period due to the Company's responsibility, the Company will replace the product with a new one or repair it free of charge.

Even within the warranty period, the warranty does not apply in the following cases:

- A) In the event of failure or damage caused by improper handling by the customer, such as dropping or impact during transportation or movement by the customer
- B) In case of failure due to disassembly or modification of the main unit by the customer
- C) In case of natural disasters such as fires, earthquakes, floods, and in case of failure or damage due to abnormal voltage

- D) In case of failure caused by failure of equipment other than the Company's designated equipment connected to the Product
- E) In case of failure of the Product's accessories (AC adapter, antenna, connection cable, etc.)
- F) If damage is caused by the failure of consumables or limited-life parts included in the Product:
 - 1. Consumables: Batteries (rechargeable, batteries, dry batteries, button batteries, etc.), recording media (SD cards, etc.)
 - 2. Limited-life parts: Various switches (limit switches, push button switches, etc.) and various sensors
 - 3. Other items that are worn out or have a service life due to useIf consumables or limited-life parts fail, we will replace or repair the parts for a fee.
- G) In case of failure caused by handling contrary to the usage and precautions described in the instruction manual of the Product
- H) If repaired, adjusted, or improved by elsewhere other than the Company
- I) If the Company is unable to reproduce the failure

3. About repair of the Product

Please note that repairing the Product requires equipment such as measuring instruments and tools, so the Company will handle it as a pick-up repair service at the Company.

4. About the shipping cost for replacement or repair of the Product

Shipping charges for sending the Product to the Company or a distributor, as well as shipping charges for sending the Product that has been replaced or repaired by the Company or the distributor to the customer, will be borne by the Company or the distributor.

5. Disclaimer

The Company is not responsible for any direct or indirect damages or monetary loss caused by failure of the Product or its use.

6. Additional notes

Please note in advance that the information of the Product described on the Company's website and in the catalogs, instruction manuals, technical materials, and other materials provided by the Company are subject to change without notice to customers.

[Repair Regulation]

This regulation (hereinafter referred to as the "Regulation") shall be applied to paid repair service (hereinafter referred to as the "Service") provided by HERUTU ELECTRONICS CORPORATION (hereinafter referred to as the "Company"). The Regulation does not apply to special order products (custom products). In addition, purchased products shall be subject to relevant manufacturer's repair regulations, and the Regulation shall not apply.

Please note that in the event that the product you purchased comes with an instruction manual

that describes the Company's old repair regulation, the latest Regulation will still apply.

1. Subject of the Regulation

The Service is provided for the Company's products that are "beyond the scope of the warranty specified in the warranty regulation" and "from the sales start date to the end date of the repair period (seven years from the production end date)". However, please note that the end date of the repair implementation period may be earlier depending on the availability and procurement status of repair parts.

2. Establishment of contract

The contract shall be established when the customer approves the quotation presented by the Company and issues an order form before the end of the repair implementation period.

3. Purpose of the Service

The Company will provide the Service for the purpose of repairing the function and performance of the Company's product used by the customer if it fails beyond the scope of the warranty specified in the warranty regulation. Please note that the Service requires equipment such as measuring instruments and tools, so the Company will handle it as a pick-up repair service at the Company.

4. Usage fee for the Service

The usage fee for the Service shall be the total of the following fees:

A) Repair service fee

The repair service fee is the total amount of technical fees, parts costs, other expenses incurred, and applicable taxes associated with repairing the Company's product (hereinafter referred to as the "Product for repair") that the customer wishes to repair.

B) Shipping fee (including the cost of packaging boxes)

The Company kindly asks that customers bear the shipping costs for sending the Product for repair to the Company and for returning it from the Company. However, in the event that the Product for repair is sent by payment on delivery by the customer, the shipping cost will be included in the Service charge.

5. Warranty period and scope of the Product for repair

The warranty period for the Product for repair is "up to six months from the date of repair completion". However, please note that failures other than the repaired parts (repaired places or replaced parts) are not covered by the warranty of the Product for repair. In addition, if a failure occurs due to the Company's responsibility within the warranty period, the Company will again repair the product free of charge.

6. Handling of repair parts

A) In order to provide the Service stably for a long time and to promote environmental protection,

etc., the Company may use recycled parts or alternative parts at the time of repair at its discretion.

- B) The Company may, at its own discretion, collect the removed parts for the purpose of recycling or analysis at the time of parts replacement through the regulation of the Service. Please note that the collected parts are the property of the Company and will be recycled, used or discarded at its discretion.

7. Estimate for the Service

The estimate for the Service is basically free of charge. However, if the Company is unable to reproduce the failure, it will not be able to carry out repairs and will not provide an estimate. If a technical investigation is required to reproduce the failure, the Company will estimate the cost of reproducing the failure.

8. Return of unrepaired product

If the Company does not estimate the cost of the Service due to reasons such as being unable to reproduce the failure, it will return the Product for repair to the customer.

In addition, if the customer does not place an order within three months from the date of creation of the quotation, or if the customer does not accept the quotation and the customer expresses an intention not to carry out the repair, the Company will assume that the customer has canceled the request for the Service, and the Company will return the Product for repair to the customer without carrying out the repair.

In addition, if a shipping fee is incurred for returning the product, it will be borne by the customer.

9. Handling of personal information

The Company will properly handle personal information such as names and addresses being provided in accordance with the privacy policy posted on the Company's website.

10. Compensation for damages

- A) The responsibility of the Company for providing the Service shall be limited to the matters and contents specified in the repair regulation, and shall not include any damages incurred by the customer due to special circumstances (including loss of profits of the customer and damages based on claims for compensation made by third parties against the customer) and damages caused by the customer being unable to use the product due to a failure or defect of the Product for repair. However, this does not apply if the damage was caused by the Company's willful misconduct or gross negligence.
- B) Even if the Company is liable to the customer for damages in connection with the regulation of the Service, the Company's liability shall not exceed the amount equivalent to the value of the Product for repair, except in cases of willful misconduct or gross negligence on the part of the Company. The value of the Product for repair shall be calculated based on the residual value after depreciation or the price of products with equivalent performance sold in the market at

the time of damage.

11. Additional notes

- A) The Company cannot restore stickers, LCD protective sheets, and coloring applied to the outer casing parts that you have attached yourself. In addition, if advertisement stickers were affixed at the time of sale, they cannot be newly prepared as repair parts when replacing the outer casing parts. After replacing the outer casing parts, the advertisement stickers will be returned without being affixed.
- B) Please note in advance that the information of the Product on the Company's website and in the catalogs, instruction manuals, technical materials, and other materials provided by the Company are subject to change without notice to customers.



HERUTU ELECTRONICS CORPORATION

422-1 Higashimikata-cho, Kita-ku, Hamamatsu, Shizuoka, 433-8104 Japan

(Sales dept) TEL.+81-53-438-3555 FAX. +81-53-438-3411

Website URL <https://www.herutu.co.jp/en/> E-mail info@herutu.co.jp