

POKAYOKE Receiver

[TWF-600R]

Operation Manual

V 1.11

HERUTU ELECTRONICS CORPORATION

62-1 Toyooka-cho, Kita-ku, Hamamatsu-shi, Shizuoka-ken, 433-8103 Japan

TEL. 81-53- 438-3555

FAX. 81-53- 438-3411

Safety concerns (Be sure to read)

To prevent human injury of user or damage in property from occurring, be sure to observe the precautions shown below.

- The degree in safety hazard and damage generated by the wrong usage while ignoring the descriptions is classified by the following displays.



Warning

Using in an improper way while ignoring this pictorial symbol might cause a death or serious human injury.



Caution

Using in an improper way while ignoring this pictorial symbol might cause a human injury or property damage.

- The type of descriptions you should observe is classified by the following pictorial symbols.



This pictorial symbol indicates a “Reminder” to attract an attention.



This pictorial symbol indicates a “Prohibition” to prohibit a certain action.



Caution

- For the usage to be commonly applied in all the models:

● Avoid using in a place with a plenty of humidity or dust. Otherwise, absorbing a dust or water contents may cause machine trouble, fire or electrical shock.



- For handling this machine:

● This is the electronic devise or wireless radios composed of the precision parts. Do not overhaul/remodel. It may cause accident or machine trouble.



Warning

- For handling this machine:

● Do not use this product for the application needing the high reliability related to human lives.













● Do not use this product in a place where it is uncertain about whether or not radio waves reach.



Warning



■ **For handling the power source:**

Be sure to observe the following precautions to prevent the AC adapter and Power cord from being heated, damaged, or ignited.

● Do not approximate the AC adapter and Power cord to a fire, or do not put them into a fire. The AC adapter and Power cord can be broken or ignited, resulting in an accident.	
● You can use the AC adapter and main body only with the specified power voltage to protect them from the damage and fire accident.	
● Do not use the AC adapter and main body in a wettable atmosphere. It may cause accidents or troubles such as heating, igniting or electrical shock.	
● Do not touch the AC adapter, main body, Power cord and Plug outlet with wet hands. It may cause an accident such as electrical shock, etc.	
● Do not damage the Power cord. A short-circuit or heating may cause a fire or electrical shock.	
● Do not use the Power plug with dust being adhered. A short-circuit or heating may cause a fire or electrical shock.	
● Do not give a strong impact onto the AC adapter. It may cause an accident or machine failure.	
● If you find out deformed AC adapter, do not use it. It may cause an accident or machine failure.	
● Do not charge this equipment in a place where flammable gas can be generated. It may cause a fire accident.	
● Never overhaul the AC adapter. It may cause an accident or machine failure.	

■ **When trouble happens during use:**

Since it may cause a fire or electrical shock, disconnect a power plug, and immediately ask outlet store or our company to repair.

● When smoke or abnormal odors are generated, stop using, immediately disconnect a power plug, and ask outlet store or our company to repair.	
● Once the Power cord is damaged, do not use it. Using it as is may cause a fire or electrical shock.	

CAUTION

CHANGE OR MODIFICATIONS NOT EXPRESSLY APPROVED BY THE MANUFACTURE FOR COMPLIANCE COULD VOID THE USER’S AUTHORITY TOOPERATE THE EQUIPMENT

**TO REDUCE THE ELECTRIC SHOCK, DO NOT REMOVE SCREWS.
NO USER-SERVICEABLE PARTS INSIDE.
REFER SERVICING TO QUALIFIED SERVICE PERSONNEL.**

THE FOLLOWNG APPLIES ONLY IN THE U.S.A

This device complies with Part 15 of the FCC Rules. Operation is subject to the following two conditions: (1)This device may not cause harmful interface, and (2) This device must accept any interface received, including interface that may cause undesired operation:

INDONESIA

This telecommunication equipment conforms to DGPT technical requirement

Contents

1. Outline	1
2. Specification	2
3. Each part name.....	4
4. Outline of operation	5
4 – 1. Normal operation	5
4 – 2. ID login	5
4 – 3. Setting the contact output time	6
5. Installation method.....	7
6. Dimensional drawing	8
7. Guarantee.....	9

Outline

1. Outline

This machine receives the frame data transmitted from Transmitter provided with software which can communicate, and actuates the corresponding output during the preset time.

The frame data transmitted from Transmitter contains ID codes equivalent to 16bit. From among 65536 type's codes, two codes, which were previously logged in this machine, can be received.

(In addition to 65536 types, the type of ID code can be further increased by adding the exclusive code.)

The codes within the received frame data are compared with the code that was previously logged in this machine, and only when they are consistent each other, the output (MOS-FET relay) goes into effect.

(Due to the preset chattering prevention time, it takes 300ms to reach receivable condition again after MOS-FET relay output.)

You can select the desired MOS-FET Relay output time from among four types of 200ms, 400ms, 600ms and 800ms.

Specification

2. Specification

General specification

Items		Specification
Model		TWF-600R
Appropriate standard/Regulation		FCC Part15B RoHS
Destination		USA
Operating power voltage		DC12V (Operative voltage zone: DC10 to 16V)
Operating power source		DC Jack Appropriate plug: Internal diameter ϕ 2.1mm External diameter ϕ 5.5mm Center-minus
Current consumption		150mA at max when DC12V is input
Working temperature/humidity range		Temperature: 0 to + 50°C Humidity: 85%RH or less (No freezing and condensation)
Electrostatic withstand pressure		10kV
Noise permissible zone		DCin 250V
Machine dimension		120W x 168H x 38D mm(Raised portion excluded)
Steel case material		Steel plate (SECC t=1.0) Painted and printed
Interface		MOS-FET Relay x 4-point (each point independently insulated) Rated load voltage AC/DC30V Rated load current 0.5A per point Connection method Screw terminal(M3.5) 8-piece
Switch	Power switch	Locker type(Alternate 2-position) 1-piece
	ID LOGIN SWITCH	Push-type(Momentary/Illuminated-type) 2-piece
Display	Power lamp	Red LED 1-piece(Light emitting section ϕ 5)
	Receiving lamp	Green LED 2-piece(Light emitting section \square 9 Also can be used as ID LOGIN SWITCH)
Accessory		Antenna (BNC Connector connected)
Option		AC Adapter Input: AC100V to 240V 50/60Hz Output: DC12V/1A

Specification

Specification of radio section

Communication system	Unidirectional communication system
Electric wave type	F1D
Modulation method	Binary FSK
Modulation rate	1000bps
Receiver frequency	426.1 MHz
Receiving circuit system	Double super heterodyne system
Receiving sensitivity	0dB μ Vemf or less
Antenna terminal	BNC-J Connector Nominal impedance 50 Ω

Each part name

3. Each part name

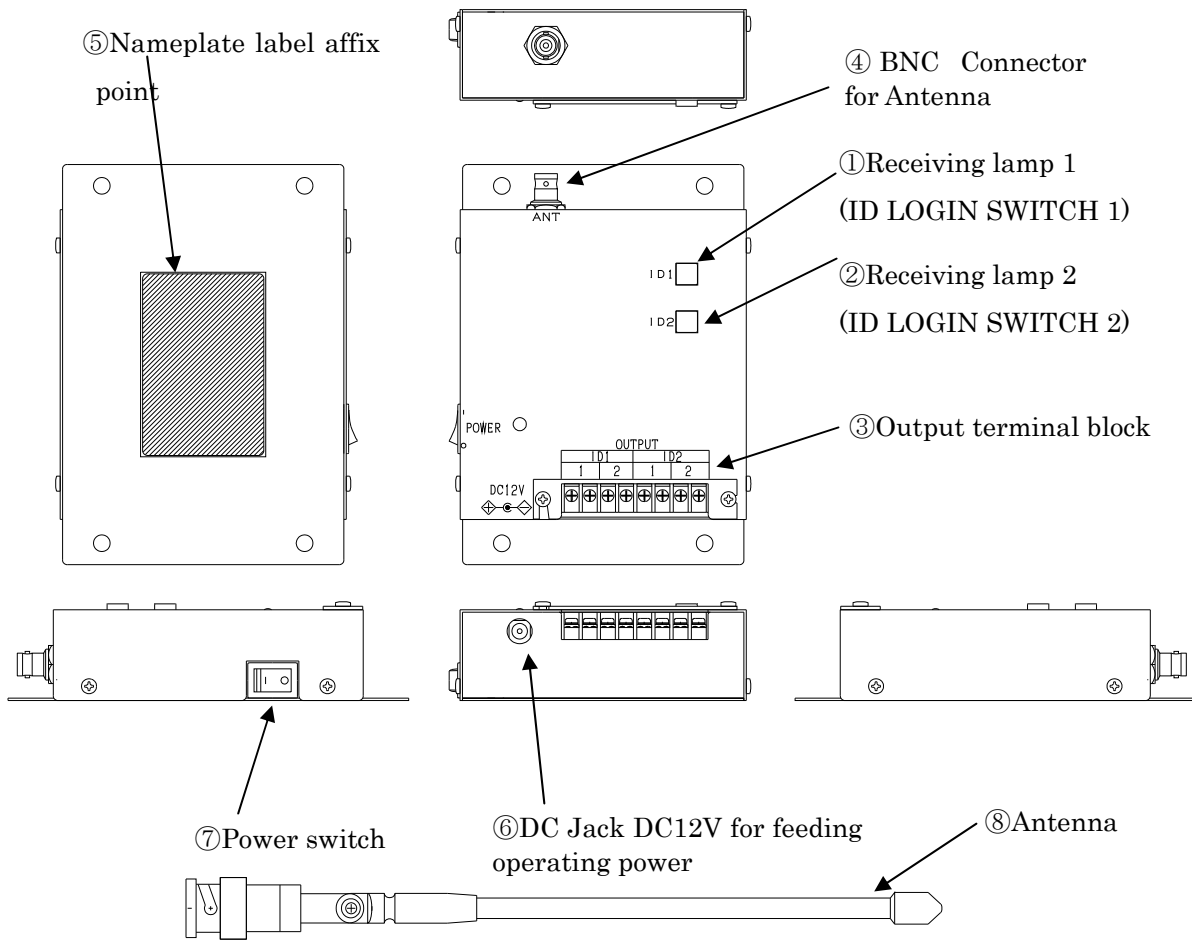

Items	Contents
①Receiving lamp 1	Receiving lamp corresponding to ID1 (Green LED) Also can be used as ID1Login switch.
②Receiving lamp 2	Receiving lamp corresponding to ID2 (Green LED) Also can be used as ID2 Login switch.
③Output terminal block	Relay output with a total of 4-point where 2-point is for ID1 and 2-point is for ID2 (Screw terminal M3.5)
④BNC Connector for Antenna	BNC-J Connector. The attached antenna is connected by this part.
⑤Nameplate label affix point	The Model, Serial No, FCC ID, IC CODE and Precautions in usage and etc are described.
⑥DC Jack for feeding operating power	DC Jack for feeding the operating power 12V Appropriate plug: internal diameter ϕ 2.1mm External diameter ϕ 5.5mm Center-minus
⑦Power switch	BNC-J Connector Nominal impedance 50 Ω
⑧Antenna	Antenna connected by BNC Connector (Accessory)

Outline of operation

4. Outline of operation

4 – 1. Normal operation

Once this machine receives two kinds of codes, namely, ID1 and ID2, which were previously logged in, the contact output of either output 1 or output 2 runs during the preset time just as Receiving lamp 1 or Receiving lamp 2 lights on depending on the received code.

When the code transmitted from Transmitter deployed can only correspond to the output 1, the output 2 becomes unused (when the input point number of Transmitter is 1-point).

You can select the desired contact output time from among four types of 200ms, 400ms, 600ms and 800ms.

Setting is already established for this machine to prevent double counting in such a way that next signal cannot be received for 300ms after the last signal is received (unacceptable to change).

4 – 2. ID login

Before using this machine, login the ID to decide the ID you need to receive.

You can login two types of ID1 and ID2. Operation can run while only ID1 is logged in with ID2 not being logged in. Besides, the same ID code for between ID1 and ID2 can be set, however, only the output for ID1 can run in this case.

Also possible to clear the already logged in ID.

Log in and clear the ID according to the following ways:

To login the ID

- ① Turn on the Power switch while pushing the Receiving lamp corresponding to the ID you need to log in.
ID1→ID LOGIN SWITCH1 ID2→ID LOGIN SWITCH2
(Receiving lamp can also be used as ID LOGIN SWITCH)
- ② Verify that the ID LOGIN SWITCH corresponding to ID you need to login is blinking (at interval of 0.5sec). If it does not blink, try again.
- ③ Within 30-second put the Transmitter of the ID you need to login into transmitting condition once.
- ④ Within 5-second without a break put it into transmitting condition again.
- ⑤ Once ID is logged in, blinking of ID LOGIN SWITCH turns into lighting.
- ⑥ After login is finished, turn off the power once and then turn on the power again before use.

Precautions during operation

*Do not operate another Transmitter in the vicinity of Receiver during login operation.
It may cause an incorrect login.

*Unless login operation is completed within the given time, the ID LOGIN SWITCH will light off. In such case, try again from the beginning.

Outline of operation

To clear the ID

- ① Turn on the Power switch while pushing the ID LOGIN SWITCH corresponding to the ID you need to login.
ID1→Receiving lamp1 ID2→Receiving lamp2
(Receiving lamp can also be used as the ID LOGIN SWITCH)
- ② Verify that the ID LOGIN SWITCH corresponding to the ID you need to login is blinking (at interval of 0.5sec).
- ③ Keep pressing the ID LOGIN SWITCH, which is blinking, for 5second.
- ④ If blinking speed becomes faster when you release ID LOGIN SWITCH, it means that clearing is completed. To use the machine without a break, turn off the power once and then turn on the power again.

4 – 3. Setting the contact output time

You can select the desired contact output time from among four types of 200ms, 400ms, 600ms and 800ms. 200ms is set before shipment.

- ① Turn on the power while simultaneously pressing two ID LOGIN Switches.
- ② Once the Power lamp starts blinking, release your hand from ID LOGIN SWITCH.
- ③ The blinking conditions of Receiving lamp indicate the current output time set values.

ID1	ID2	Contact output time
lights off	lights off	0.2sec
lights on	lights off	0.4sec
lights off	lights on	0.6sec
lights on	lights on	0.8sec

- ④ To change the setting, manipulate the ID LOGIN SWITCH within 5 seconds.
Once ID LOGIN SWITCH is pressed, the “lights on/lights off” will reverse. Manipulate the ID LOGIN SWITCH to get the contact output time you need to set.
- ⑤ Once 5-second passes after stopping ID LOGIN SWITCH manipulation, the set content can be logged in.
If login is completed, all ID LOGIN Switches lights off and blinking of power lamp turns into lighting. Then you can operate as-is continuously.

Precautions during operation

- *The contact output time is common. It is impossible to set the different output time for each ID.
- *If you do not change the setting, wait for 5-second without manipulating ID LOGIN SWITCH after the condition of ③ or turn off the power switch.
- *If the power switch is turned off during power lamp in blinking, the set content cannot be logged in.

Installation method

5. Installation method

- ① Install this machine in the place where it can be easily viewed from the Transmitter and also an electric wave can be stably received.
- ② Set the antenna so that it is not parallel to the metal plates and keep away it from metal plates as far as possible.
- ③ Feed the stable power supply (DC12V) with less variation.
- ④ Make a wiring for the output terminal block.

Output turns on with relay contact. Once output turns on, short-circuited condition is made between terminals.

Once the rated contact load is exceeded, inner circuit might be damaged. Use an extreme care.

Rated load voltage AC/DC30V per point Rated load current 0.5A per point Connection method Screw terminal(M3.5) 8-piece

<TWF-600R Output terminal Block>

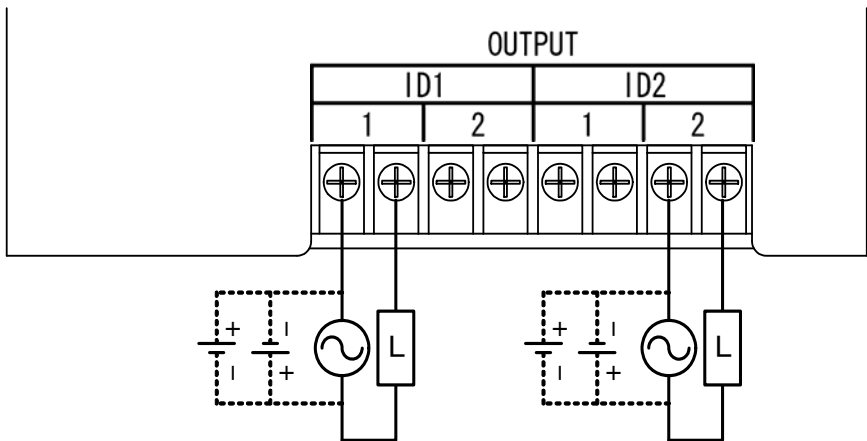

<External Connections>

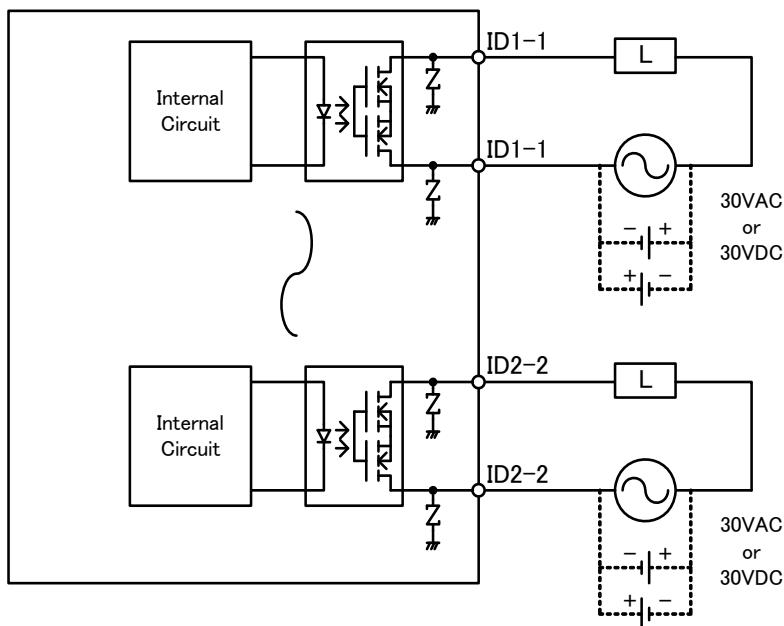

Dimensional drawing

6. Dimensional drawing

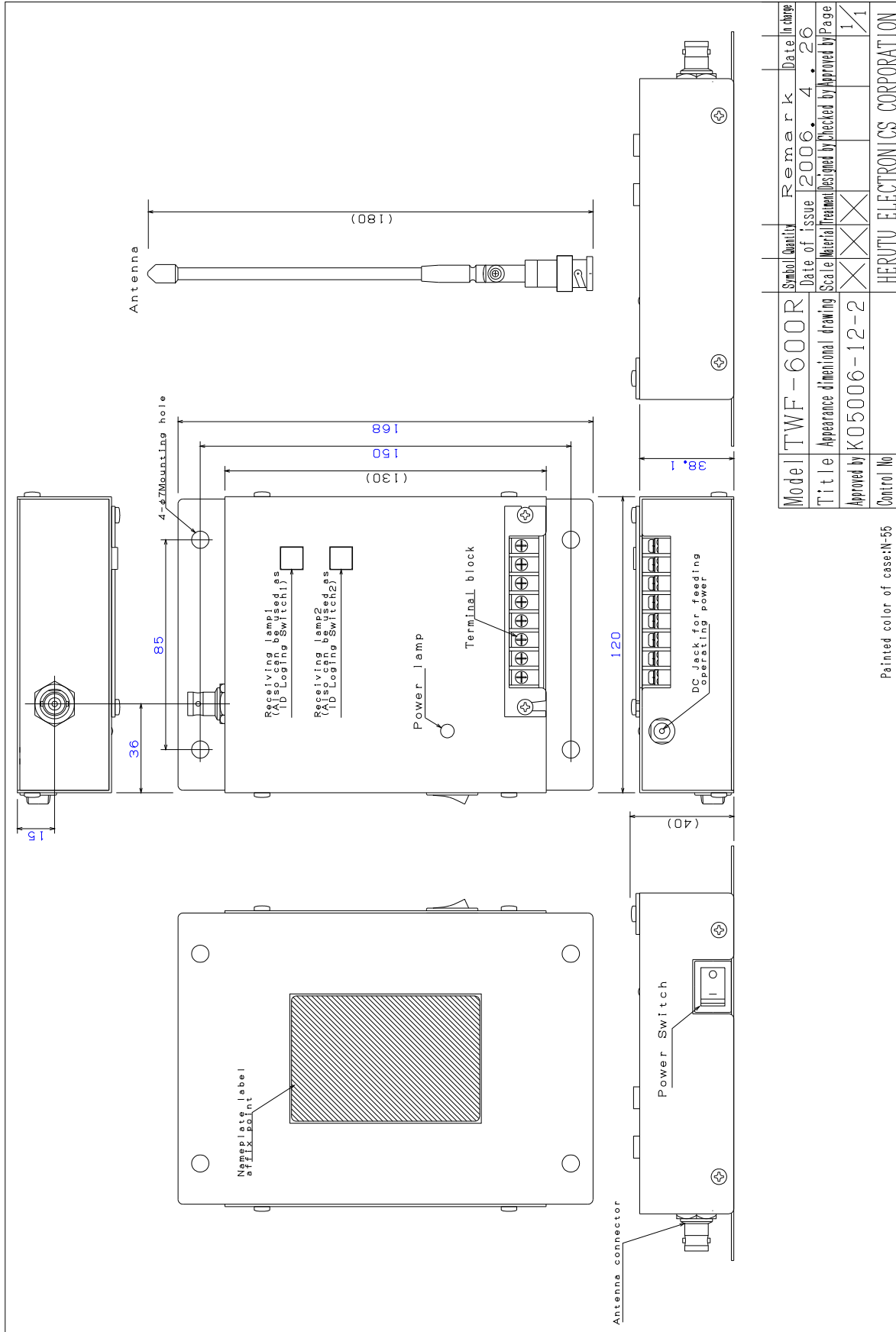

Model	TWF-600R	Symbol	Quantity	Remark	Date	In charge
Title	Appearance dimensional drawing	Date of issue	2006.4.26	Scale	Material Treatment	Designed by / Checked by / Approved by / Page
Approved by	K05006-12-2		×	×	×	1/1
Control No						

Painted color of case: N-55

HERUTU ELECTRONICS CORPORATION

Guarantee

7. Guarantee

■ Provisions of warranty

The provisions of warranty are set forth by us for warranty of the product after shipment so that the product can be used with a sense of security after purchased. In case our product is out of order, we will provide repair or replacement under the provisions of warranty.

■ Scope of warranty

If the product should get out of order under the normal conditions of use by the customer, we will repair the failed section(s) free of charge subject to the provisions of warranty. Please contact the outlet store through which you purchased the product or our Sales Office. Note, however, that free-of-charge repair under this warranty is limited to the hardware components of the product.

Even during the warranty period, the customer shall be responsible for repair cost if any of the following applies:

1. Troubles or damages occurring due to improper handling by the customer, such as a fall, a shock, etc. during transportation or movement of the product by the customer.
2. Troubles caused by overhaul or remodeling of the main body by the customer.
3. Troubles or damages caused by fire, earthquake, flood damage, or other natural disasters, as well as by abnormal voltage.
4. Troubles resulting from any trouble of devices connected to the product, which devices are other than those designated by us.
5. Troubles with the accessories (AC adapter, antenna, connection cables, or the like) except the main body.
6. Replacement of consumables and/or limited-life items (including batteries).
Consumables and limited-life items include, but not limited to:
 - (1) Switches (limit switches, pushbutton switches, or the like)
 - (2) Battery cells or batteries (dry batteries, button batteries, or the like)
 - (3) Other items subject to consumption or limitation of life caused by use.
7. Troubles occurring due to handling against the use instructions or precautions specified in this operation manual.

■ Warranty period

In principle, the warranty period shall last one (1) year from the date of purchase.

During the warranty period, we will provide free-of-charge repair subject to the provisions of warranty set forth in the warranty certificate.

If you have anything unclear about the repair or follow-up service during the warranty period, please contact the outlet store through which you purchased the product or our Sales Office.

■ Initial defects

The period within two (2) weeks from the date of purchase is defined as the initial defect period for the product. The product will be replaced with a new one or repaired free of charge provided that it is returned to the outlet store through which you purchased the product or our Sales Office, checked, and recognized as having initial defects.

Guarantee

For initial defects, we shall be responsible for the shipping cost.

■ Disclaimer

We will assume no liability for any damages or monetary losses, direct or indirect, arising out of troubles, failures, or use of the product.

■ Repair service period

The repair service for the product will be available for eight (8) years from the date of purchase.

However, we reserve the right to use substitute parts or devices for repairing purposes if there are unavoidable reasons such as unavailability of service parts.

■ Others

- Independent of the warranty period, the product to be repaired shall in principle be brought into our site because of the necessity of using measuring instruments or the like for adjustments etc., and the shipping cost etc. incurred in bringing the product into our site shall be borne by the customer.

In such cases where you request a trip to your place for repair or need substitute devices during the warranty period, please contact the outlet store through which you purchased the product or our Sales Office.

We reserve the right to refuse replacement or repair if we are unable to reproduce the concerned failure at our engineering department after receipt of a request for repair. In addition, an additional charge may be made to the customer for the technical examination cost incurred in reproducing the failure.

- The provisions of warranty are effective in Japan only.
- For repair service after the expiration of the warranty period, please contact the outlet store through which you purchased the product or our Sales Office.

If the functionality can be maintained by means of repair, repair will be provided on a fee basis upon the customer's request.

The information in this manual is subject to change without prior notice.
All possible measures are taken to ensure the accuracy of information in this manual. If you should find any doubtful points herein, please contact the outlet store through which you purchased the product or our Sales Office.
The specifications and appearance of the product are subject to change without notice for improvements.

<CONTACT US>



HERUTU ELECTRONICS CORPORATION

62-1 Toyooka-cho, Kita-ku, Hamamatsu-shi, Shizuoka-ken, 433-8103 Japan

Tel.81-53-438-3555

Fax.81-53-438-3411

URL: <http://www.herutu.co.jp> Mail: webmaster@herutu.co.jp

