

Wireless equipment for Torque wrench Receiver

TW-510R
TW-510RD
TW-510RW
TW-510RDW

Instruction Manual V1.20



Please use this Instruction manual correctly on reading well.
Please keep it carefully to be able to read immediately, when required.

To use this product in safety and comfort, (Be sure to read)



Thank you very much for purchasing our product.

This operation manual contains the precautions necessary for preventing an accident caused by the use in an improper ways.

Read it carefully while thoroughly understanding the meanings of pictorial symbols.

 Warning	Using in an improper way while ignoring this pictorial symbol might cause a serious human injury.
 Caution	Using in an improper way while ignoring this pictorial symbol might cause a human injury or physical damage.

- The type of precautions that should be observed, are classified using the following pictorial symbols.

	This pictorial symbol indicates a "Reminder" to attract an attention.
	This pictorial symbol indicates a "Prohibition" to prohibit a certain action.

Caution

- For the usage to be commonly applied in all the models:

- Avoid using in a place with a plenty of humidity or dust. Otherwise, absorbing a dust or water contents may cause machine trouble, fire or electrical shock.



- For handling this machine:

- This is the electronic devise or wireless radios composed of the precision parts. Do not overhaul/remodel. It may cause accident or machine trouble.





Warning

■ For handling this machine:

● Do not use this product for the application needing the high reliability related to human lives.	
● Do not use this product in a place where it is uncertain about whether or not radio waves reach.	

■ For handling the power source:

Be sure to observe the following precautions to prevent the AC adapter and Power cord from being heated, damaged or ignited.

● Do not approximate the AC adapter and Power cord to a fire, or do not put them into a fire. The AC adapter and Power cord can be broken or ignited, resulting in an accident.	
● You can use the AC adapter and main body only with the specified power voltage to protect them from the damage and fire accident.	
● Do not use the AC adapter and main body in a wettable atmosphere. It may cause accidents or troubles such as heating, igniting or electrical shock.	
● Do not touch the AC adapter, main body, Power cord and Plug outlet with wet hands. It may cause an electrical shock.	
● Do not damage the Power cord. A short-circuit or heating may cause a fire or electrical shock.	
● Do not use the Power plug with dust being adhered. A short-circuit or heating may cause a fire or electrical shock.	
● Do not give a strong impact onto the AC adapter. It may cause an accident or machine failure.	
● If you find out deformed AC adapter, do not use it. It may cause an accident or machine failure.	
● Do not use this product in a place where flammable gas can be generated. It may cause a fire accident.	
● Never overhaul the AC adapter. It may cause an accident or machine failure.	

■ When trouble happens during use:

Since it may cause a fire or electrical accident, disconnect a power plug, and immediately ask outlet store or our company to repair.

● When smoke or abnormal odors are generated, stop using, immediately disconnect a power plug, and ask outlet store or our company to repair.	
● Once the Power cord is damaged, do not use it. Using it as is may cause a fire or electrical accident.	

***This operation manual is translated a product for Japan into English/**

This product is based on Japanese Wireless law.

This operation manual contains the instruction for "TW-510R", and also for "TW-510RW", "TW-510RD" and "TW-510RDW". Please understand that some parts of this manual describes about "TW-510RW", "TW-510RD" and "TW-510RDW" as an option for value.

For the model and available frequency, see the product number seal attached on side of the machine.

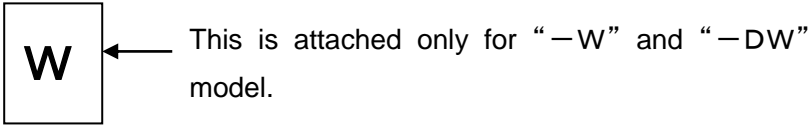
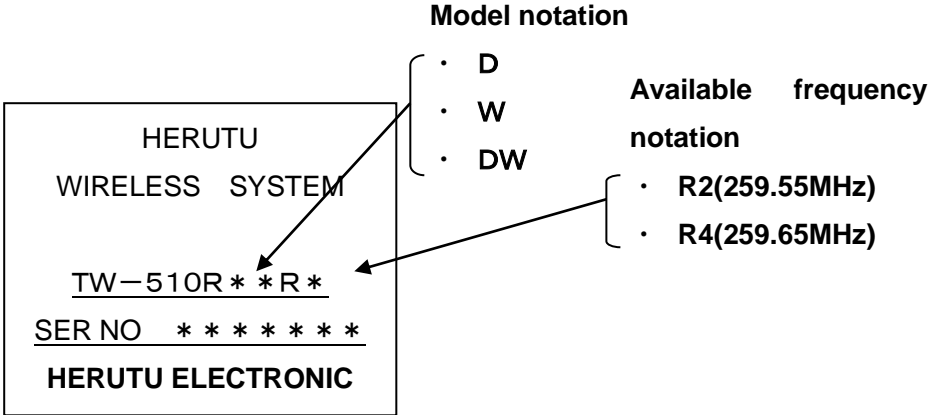

Contents

1.General descriptions	1
2.Specification	2
3.Names and functions of each part	4
4.Outline of operation	6
5.Operational setting	8
5-1.To set the ID	8
5-2.Each setting	9
5-3.To set the double count prevention time	10
5-4.To set the relay (OUT1 and 2) output time	10
6.Dimension drawing	12
7.Installation method	13
8.Troubleshooting	14
9.Maintenance	15
10.Warranty	16

Appendix 1

Setting conversion table

1.General descriptions

1.General descriptions

This machine is used combined with our Radio transmitter for Torque wrench(hereinafter abbreviated as "TW-510T"). (Use this machine in combination with the Transmitter of the same radio frequency.)

Once the tightening completion signal is received from "TW-***t" , the relay turns on just as buzzer sounds.

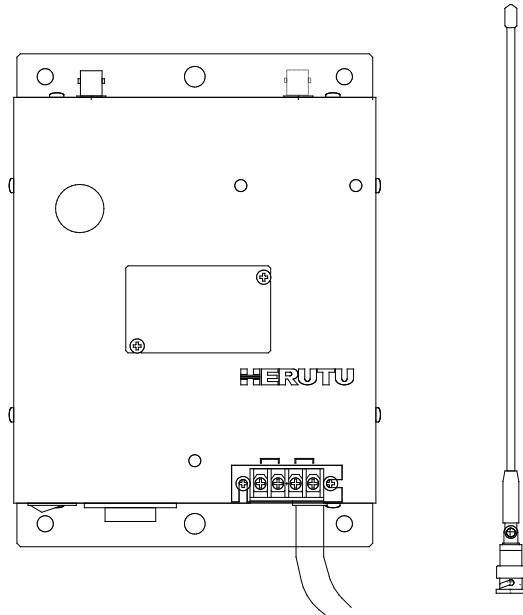

- The wireless communication using the weak radio wave of 259MHz zone with less noise detects an error during receiving to achieve the reliable form of communication with fewer malfunctions.
- The relay output time and double count prevention time can be set by the rotary switch.
- The ID can be set up to 256-type.
- The built-in Output AC plug outlet is well suited for installing the Receivers with being lined up.

For the "TW-510R", the following models are available as an option (for value) before shipment.

- TW-510RD : "Diversity type" Receiver consisting of two receiving modules where two antennas can be installed, which enables the stable communication under the poor environment.
- TW-510RW : "Two-unit receiving type" Receiver that can individually process the signals transmitted from two Transmitters of different ID. This is used for the application where one operator uses the Torque wrenches of different types and also those each device should be separately controlled.
- TW-510RDW : This is the model combined with both functions of the above "RD" and "RW" type.

2.Specifications

2.Specification

Items	Specifications	Remarks
Model	TW-510R	
	Diversity type TW-510RD	
	2-unit Receiving type TW-510RW	
	Diversity type + 2-unit Receiving type TW-510RDW	
Available frequency	Either 259.55MHz(R2) or 259.65MHz (R4) wave	Fixed before shipment
Attached antenna	Whip antenna: approx. 310mm in overall length	Model : HTM-5B
	For the TW-510RD & RDW model, the External antenna available: Approx. 310mm element and 4m connection cable	Model : HTG-300-4
Operating power voltage	AC100V 50/60Hz	
Power cord	VCTF 1.25mm ² Length : approx. 2m	
Power consumption	15W or less	
Working temperature	0 to +50°C No dew drop	
Size	157.4W x 177H x 41Dmm (Projection and Mounting bracket not included)	
Weight	Approx. 1.1kg	
Receivable ID number	Set one type out of 256-type.	Set it with the 8-verse DIP Switch
	For the TW-510RW model, set two types out of 256-type.	
Display	Power (POW) LED (Red) Φ5×1	
	LED(Green)for receiving RX1:Φ5×1	
	LED(Green)for receiving RX2:Φ5×1	Only available for Diversity type
Buzzer	Electronics buzzer for high sound volume type device Sound frequency : approx. 2.3kHz Sound volume : 95±10dB (1m in distance)	Directivity available
Output	Output : Relay contact outputx 2 -For ID1(OUT1)×1 -For ID2(OUT2)×1 Max rated relay contact load (resistance load) AC250V5A or DC30V5A	OUT2 is only available for 2-unit Receiving type

2.Specifications

Setting Switch	Rotary switch (10-type selective) ×2 pcs -For setting output timex1 -For setting double counting prevention timex1	
	8-verse DIP switch×3 pcs ① For setting ID1×1 ② For setting ID2×1 ③ For setting function×1	DIP SW for ID2 is only available for 2-unit Receiving type.
Switch	Power SW×1pce (Locker type)	
Other outputs	Output AC plug outlet×1pce (Individual-Control-type Power Switch: Max load current 125V 12A)	
Accessories	Operation manual (this manual) × 1 copy Antenna (HTM-5B) ×1 pce Guarantee certificatex1 copy	
	For the TW-510RD, RDW model, the External antenna(HTG-300-4)×1-unit is available in addition to the above contents.	

Note) Communication may not run in a place with heavy radiation noise emitted from the electrical welding equipment. If communication does not run even in close range, the dead point, which was vanished by the reflected electric wave, might have occurred. In such a case, use the Diversity model.

3.Names and functions of each part

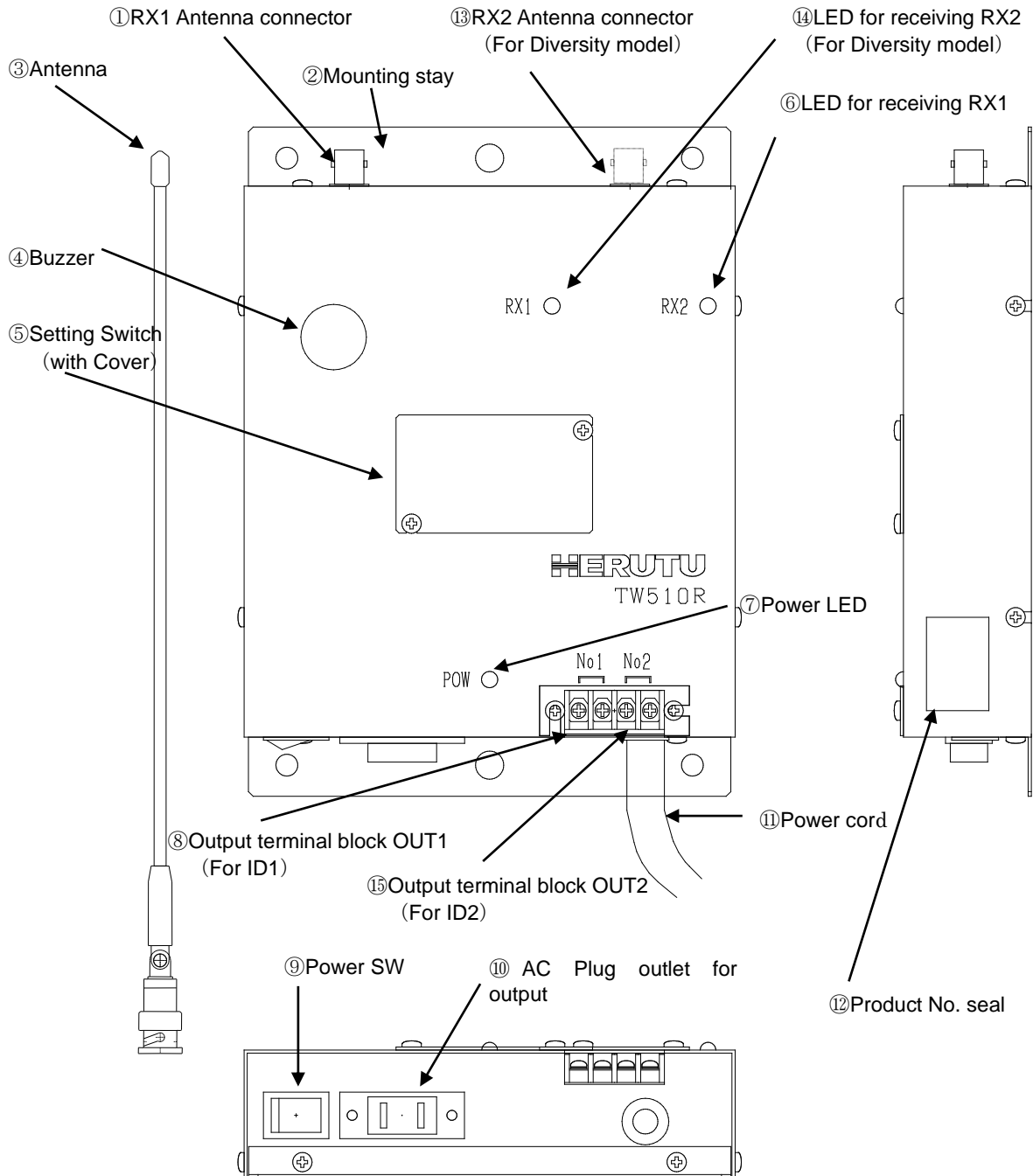

Function enclosed within this frame is effective for optional models.

- ① RX1 Antenna connector : connects the attached antenna(HTM-5B)
Connector type BNC-J (Connector for single antenna)
- ② Mounting stay : used to install this machine (6-slot)
- ③ Antenna : connected to RX1 Antenna connector.
- ④ Buzzer : emits a single sound when it receives the tightening completion signal from the TW-510T.
- ⑤ Setting Switch : Two Rotary switches and three Dip switches are available for each setting.

3.Names and functions of each part

- ⑥ LED for receiving RX1 : keeps lighting for 0.2 second when receiving the tightening completion signal through the RX1 antenna.
- ⑦ Power LED : keeps lighting during Power supply ON.
- ⑧ Output terminal block 1 : Relay turns on when the tightening completion signal of ID1 is received. (OUT1)
- ⑨ Power SW : turns ON/OFF of machine power supply.
- ⑩ AC Outlet plug for output : directly outputs the AC100V fed through the power cord.
Output does not run in conjunction with Power SW. Operation is only permitted within max 125V 12A load current.
- ⑪ Power cord : feeds the power for operation. Supply the AC100V 50/60Hz.
- ⑫ Product No. seal : Product number and radio frequency are stated. For the radio frequency, R2→259.55MHz and R4→259.65MHz.

Names and functions of parts used for [TW-510RD, RW, DRW] model:

- ⑬ R X 2 Antenna connector : Only for the TW-510RD model, BNC type connector is available. This connector connects the attached external antenna (HTG-300-4). Connector type : BNC-J
[Available for "RD"/"RDW" model]
- ⑭ LED for receiving RX2 : keeps lighting for 0.2 second when RX2 antenna receives the tightening completion signal.
[Available for "RD"/"RDW"]
- ⑮ Output terminal block2 : Relay turns on when the ID2 tightening completion signal is (OUT2) received. [Available for "RW"/"RDW"]

External antenna : connected to the Diversity type antenna connector when Diversity model is used. This is the magnet base type provided with 4m cable.
(Model: HTG-300-4)

[Available for "RD"/"RDW" model]

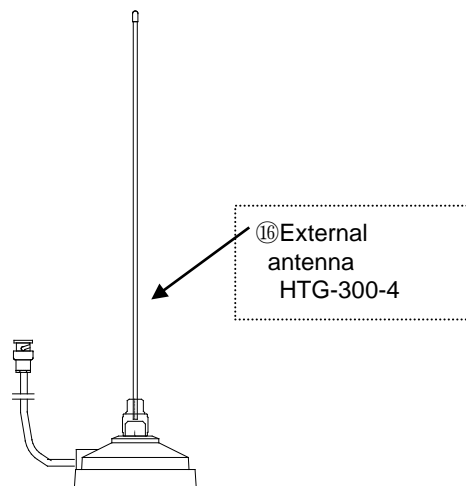

4.Outline of operation

4.Outline of operation

Once this machine “TW-510R” receives the signal from “TW-**T”, buzzer sounds and relay turns on. The contents shown below can be set at your discretion using the setting SW:

- ID setting
- Relay output time setting
- Double count prevention time setting
- Buzzer sound Effective/Ineffective

If you use the “TW-510R” combined with the “TW-510T”, the receivable ID is one type and the single antenna type is available. However, as an option for value, the following three types are also available. Choose the type depending on your application.

Model	Antenna	Receivable ID
TW-510RD	Diversity antenna	1-type(1-unit receiving)
TW-510RW	Single antenna	2-type(2-unit receiving)
TW-510RDW	Diversity antenna	2-type(2-unit receiving)

● 1-unit Receiving

“TW-510R” of one unit is used for “TW-510T” of one unit.

“TW-510R” communicates with the Transmitter with the same ID as the one, which was set by the DIP Switch for setting the ID1.

Once this machine receives a signal, the RX1LED keeps lighting for 0.2 second and it is outputted to the OUT1 only during the preset output time. If Buzzer output is set at “Effective” at that time, buzzer sounds in synchronization with the OUT1.

The next receive restarts after the lapse of double counting prevention time after OUT1 output turns off.

[Outputs from ID1→OUT1]

● 2-unit Receiving Model : “RW”

“TW-510RW” of one unit is used for “TW-510T” of two units.

Once “TW-510RW” receives the ID, which was set by the DIP switch for setting ID1, it sends the signal to OUT1.

If this machine receives the ID, which was set by the DIP Switch for setting ID2, it sends the signal to OUT2.

Once this machine receives a signal, the RX1LED keeps lighting for 0.2 second and it is outputted to either OUT1 (ID1) or OUT2 (ID2) only during the preset output time. If Buzzer output is set at “Effective” at that time, buzzer sounds in synchronization with either OUT1 (ID1) or OUT2 (ID2).

4.Outline of operation

The next receive restarts after the lapse of double counting prevention time after either OUT1 (ID1) or OUT2 (ID2) turns off.

[Outputs from ID1→OUT1] [Outputs from ID2→OUT2]

- * The “RW””RDW”type can receive two types IDs by setting two types ID, however, cannot receive two types IDs which were simultaneously transmitted from the “TW— * * * T”.
(OUT1 and OUT2 cannot turn on simultaneously)

- Diversity receiving Model : “RD”

This model is used both for 1-unit receiving (ID1) and 2-unit receiving (ID1, ID2). The different point with the single antenna is that two antennas can be used to improve the receiving capacity. In addition to the normal antenna 1 (HTM-5B), the External antenna is connected on the Connector for Diversity antenna (Antenna 2).

Once the Antenna 1 receives a signal, RX1LED lights on, on the other hand, once the Antenna 2 receives a signal, the RX2LED lights on.

5.Operational setting

5.Operational setting

To set the “TW-510R”, use the Set switch at center of front side of machine.

Loosen the cover screw and remove the cover before setting.

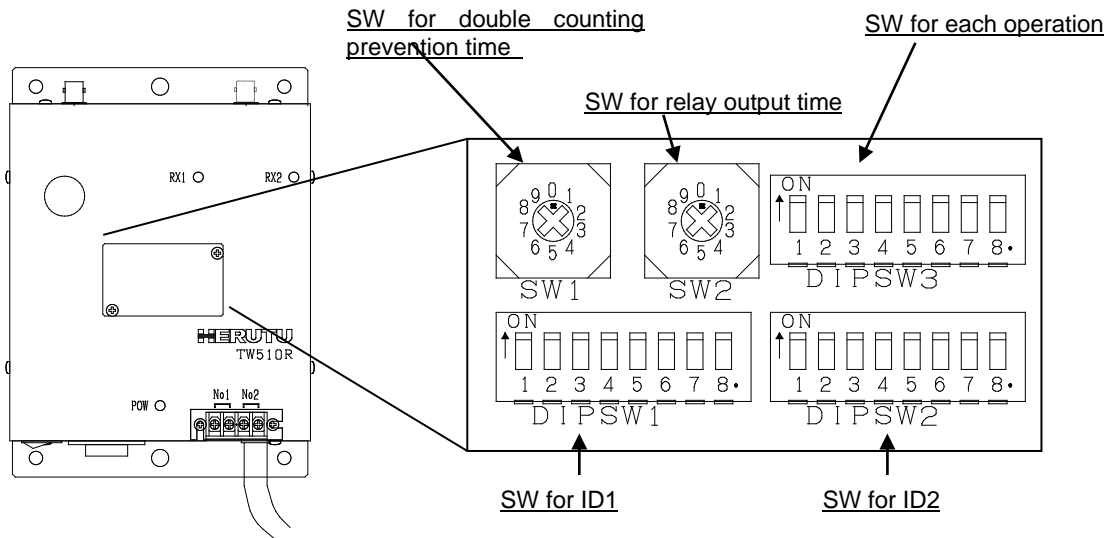

5-1.To set the ID

Set the same ID as the one of TW-510T.

To set the ID, use the 8-verse DIP Switch 1(DIPSW1). The ID is normally represented by “0” to “255” in decimal notation; however, for setting into this machine, convert it into the binary notation.

Carry out setting according to the Setting conversion table (appendix 1).

ID1: 0 to 255

- For “TW-510R-W”/”TW-510RDW” model,
For ”RW”/”RDW”model as an option, you can set the ID2 in addition to the normal ID1. To set the ID2, use the 8-verse DIP Switch 2 (DIPSW2).

ID2: 0 to 255

For “TW-510R” model, the setting of DIPSW2 is disabled.

For “TW-510RW”/”TW-510RDW” model, if ID1 and ID2 are set to the same contents, signal turns on only through the Output terminal block 1.

Be sure to turn off the power supply before changing the setting.

5.Operational setting

5-2.Each setting

To set the buzzer sounding for “TW-510R”, “TW-510RD”, “TW-510RW” and “TW-510RDW”, use the No.3 of 8-verse DIP Switch (DIPSW3).

Be sure to turn off the power supply before changing the set contents.

DIPSW3	Functions	ON	OFF
1	Fixed before shipment	* * *	* * *
2	Fixed before shipment	* * *	* * *
3	Buzzer sound	Sound	Does not sound
4	Fixed before shipment	* * *	* * *
5	Fixed before shipment	* * *	* * *
6	Fixed before shipment	* * *	* * *
7	Fixed before shipment	* * *	* * *
8	Fixed before shipment	* * *	* * *

① Buzzer setting

To set the buzzer for “Sound”/“Does not sound”, use the DIPSW 3-3.

OFF→Does not sound

ON→Sound

**DIPSW3-1,2 and 4 to 8 are fixed before shipment.
Do not change them.**

5.Operational setting

5-3.To set the double count prevention time

You can set the time for disabling the next receiving as the double counting prevention time after a signal is received from “TW-510T” and outputted to OUT1 (or OUT2).

Set proper values to prevent the double counting by the “TW-***T”.

To set the double counting prevention time, use the Rotary switch 1.

For the preset time, you can set it ranging from 0.1 to 1.0 seconds at interval of 0.1 second.

(10-type)

ROT_SW1

Switch	0	1	2	3	4	5	6	7	8	9
Preset time (second)	0.1	0.2	0.3	0.4	0.5	0.6	0.7	0.8	0.9	1.0

*“0.2second” (Switch 1) is already set before shipment.

5-4.To set the relay (OUT1 and 2) output time

You can set the time for outputting a signal to OUT1 (or OUT2) after receiving it from “TW-***T”.

The relay output time synchronizes with the buzzer sound time.

Set the proper values depending on the device on which relay output is connected.

To set the relay output time, use the Rotary switch 2.

For the preset time, you can set it ranging from 0.2 to 1.1 seconds at interval of 0.1 second.

(10-type)

ROT_SW2

Switch	0	1	2	3	4	5	6	7	8	9
Preset time (second)	0.2	0.3	0.4	0.5	0.6	0.7	0.8	0.9	1.0	1.1

*“0.3second”(Switch 1) is already set before shipment.

5.Operational setting

TW-510T

Transmit signal

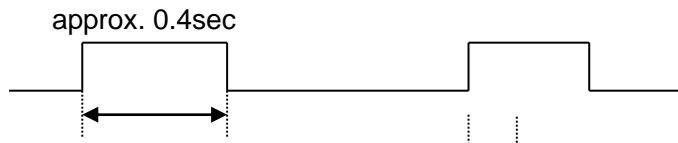

Relay output time
0.2 to 1.1sec

TW-510R

OUT Output

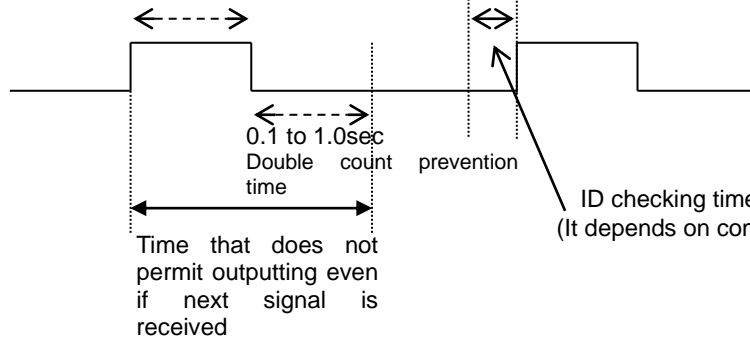

6. Dimensional drawing

6. Dimensional drawing

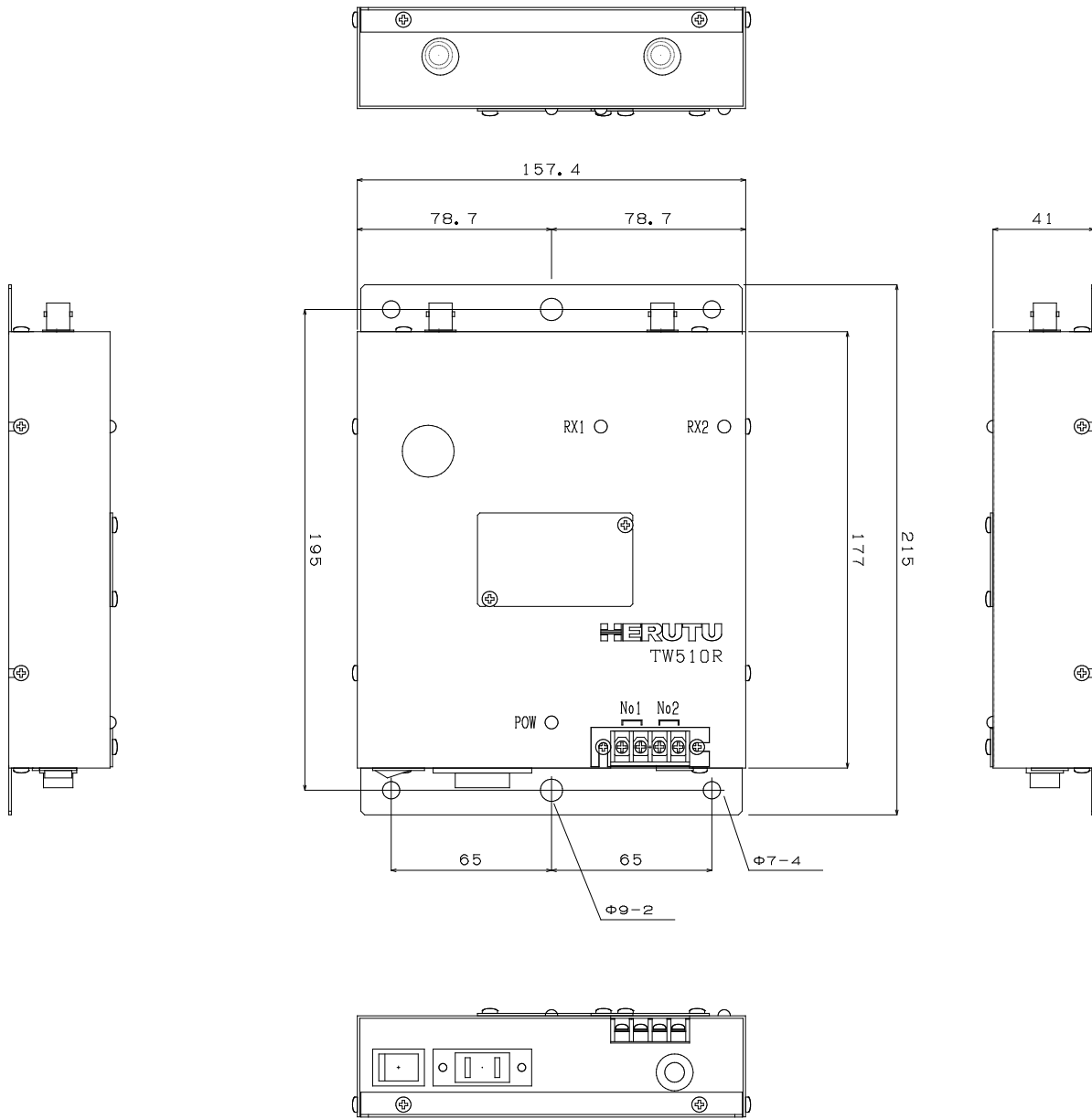

Note : The figure shows "TW-510RD" and "TW-510RDW" type.

For "TW-510R" and "TW-510RW" model, BNC connector is only RX1.

7.Installation method

7.Installation method

- ① Install this machine in the place where it can be easily viewed from the Transmitter (“TW-**T”) and an electric wave can be stably received.

If communication is unstable, we recommend you to use the Diversity type antenna (TW-510RD).

- ② Set the antenna so that it is not parallel to the metal plates and keep away it from metal plates as far as possible.

- ③ If you use the “TW-510RD” or “TW-510RDW”, the External antenna (HTG-300-4) to be connected on the RX2 antenna connector should be kept away from the Antenna(HTM-5B) connected on the RX1 antenna connector as far as possible.

If you use the External antenna (HTG-300-4), the antennas at two location enable the wide angle receiving, so that an electric wave from Transmitter (TW-***T) can be more effectively received compared with the one by use of one antenna.

- ④ Feed the stable power supply (AC100V) with less variation.

To install this machine in a lot, use the Output AC Plug outlet.

However, use a care not to exceed the rated load current when you connect to the Output AC Plug outlet.

Max load current AC125V 12V or less

- ⑤ Make a wiring for the output terminal block.

Output turns on with relay contact. Once output turns on, short-circuited condition is made between terminals, so that you can install the revolving light or horn.

If exceeding the rated contact load, internal circuit might be damaged. Use an extreme care.

**Max rated contact load AC250V5A or DC30V5A
(Resistance load)**

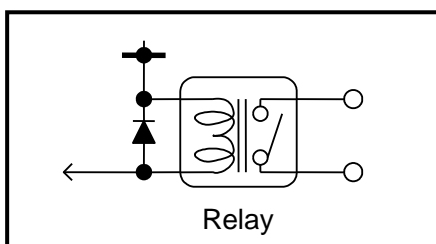

Output section

8.Troubleshooting

8.Troubleshooting

Phenomena	Causes and remedies
Power LED does not light on even after power is turned on.	Power does not come
	Feed the power
Signal from TW-***T is not counted	ID is not matched
	Check this machine for the set content, and allow it to be consistent with the ID of "TW-***T".→see page 8
	The double counting prevention time runs.
	After inputting 1 count, count inputting for up to the preset time is disabled. Change the double counting prevention time. →see page 10
	"TW-***T" does not transmit an electric wave.
	Carry out transmission test for "TW-***T".
	Machine is being used for outside the electric wave access range.
	Check the antenna for installation place. Check the optional external antenna and diversity antenna for their models.
Buzzer does not sound	Wireless frequency is not matched.
	Check that the wireless frequency(R2 and R4) stated on Product No seal is matched with the one of "TW-***T".→see page 5.
Buzzer does not sound	Buzzer is set to OFF.
	Set the Buzzer Set Switch at "Sound". →see page 9.
Double receiving function does not run	Optional function is not built in.
	Only the "RW"/"RDW" model with optional function enables the double receiving function.
Diversity antenna does not function	External antenna(HTG-300-4) is closely installed to the body antenna (HTM-5B) .
	Keep away the external antenna (HTG-300-4) from body antenna (HTM-5B) as far as possible when installing.→see page 12.

9.Maintenance

9.Maintenance

In the unlikely event that you find trouble during use under normal conditions, see “7. Troubleshooting”. If problems cannot be solved after taking necessary actions or countermeasures are unclear, inform the contents stated below to the outlet store through which you purchased or our sales office.

<p>Product name / Production No. / Service environment, External devices connected, Operating procedures taken until trouble happens, and Concrete trouble contents</p>
--

HERUTU ELECTRONICS CORPORATION

TEL81-53-438-3555 FAX81-53-438-3411

10.Warranty

10.Warranty

■ Provisions of warranty

The provisions of warranty are set forth by us for warranty of the product after shipment so that the product can be used with a sense of security after purchased. In case our product is out of order, we will provide repair or replacement under the provisions of warranty.

■ Warranty period

Besides, as long as there is not providing, the warranty period shall be 13 months after shipping the products. During the warranty period, we will provide free-of-charge repair subject to the provisions of warranty set forth in the warranty certificate.

If you have anything unclear about the repair or follow-up service during the warranty period, please contact the outlet store through which you purchased the product or our Sales Office.

■ Scope of warranty

If the product should get out of order under the normal conditions of use by the customer, we will repair the failed section(s) free of charge or exchange the new one free of charge subject to the provisions of warranty. Please contact the outlet store through which you purchased the product or our Sales Office.

Also, the warranty period shall be 13 months after shipping the product or shall be 6 months after shipping substituting goods. The warranty periods will be applied the period visited later.

Note, however, that free-of-charge repair under this warranty is limited to the hardware components of the product. Even during the warranty period, the customer shall be responsible for repair cost if any of the following applies:

1. Troubles or damages occurring due to improper handling by the customer, such as a fall, a shock, etc. during transportation or movement of the product by the customer.
2. Troubles caused by overhaul or remodeling of the main body by the customer.
3. Troubles or damages caused by fire, earthquake, flood damage, or other natural disasters, as well as by abnormal voltage.
4. Troubles resulting from any trouble of devices connected to the product, which Devices are other than those designated by us.
5. Troubles with the accessories (AC adapter, antenna, connection cables, or the like) except the main body.
6. Repairing, adjustment, modification by except our company
7. Replacement of consumables and limited-life items (including batteries).
Consumables and limited-life items include, but not limited to:
 - (1) Switches (limit switches, pushbutton switches, or the like)
 - (2) Battery cells or batteries (dry batteries, button batteries, or the like)
 - (3) Other items subject to consumption or limitation of life caused by use.

10. Warranty

8. Troubles occurring due to handling against the use instructions or precautions specified in this operation manual.

■ Initial defects

The period within 30 days from the date of shipping the product is defined as the initial defect period for the product. The product will be replaced with a new one or repaired free of charge provided that it is returned to the outlet store through which you purchased the product or our Sales Office, checked, and recognized as having initial defects. For initial defects, we shall be responsible for the shipping cost.

But it is in Japan only. In case of purchasing the products out of Japan, it will be decided after conference about shipping cost for returning back, insurance cost, custom duty.

■ Disclaimer

We will assume no liability for any damages or monetary losses, direct or indirect, arising out of troubles, failures, or use of the product.

■ Repair service period

Only if we have the stock of parts for repairing, even if after finishing the warranty period, we will repair the product within 5 years after end of production for a fee.

However, we reserve the right to use substitute parts or devices for repairing purposes. If there are unavoidable reasons such as unavailability of service parts.

■ Others

- Independent of the warranty period, the product to be repaired shall in principle be brought into our site because of the necessity of using measuring instruments or the like for adjustments etc., and the shipping cost etc. incurred in bringing the product into our site shall be borne by the customer.
- In such cases where you request a trip to your place for repair or need substitute devices during the warranty period, please contact the outlet store through which you purchased the product or our Sales Office. We will correspond for a fee.
- We reserve the right to refuse replacement or repair if we are unable to reproduce the concerned failure at our engineering department after receipt of a request for repair. In addition, an additional charge may be made to the customer for the technical examination cost incurred in reproducing the failure.
- The information in this manual, our website, catalog we supply, is subject to change without prior notice. Please be forewarned.



HERUTU ELECTRONICS CORPORATION

422-1 Higashimikata-cho, Kita-ku, Hamamatsu, Shizuoka, 433-8104 Japan

(Sales dept) TEL.+81-53-438-3555 FAX. +81-53-438-3411

Website URL <https://www.herutu.co.jp/en/> E-mail info@herutu.co.jp